

TRS-80[®] Pocket Computer

Printer/Cassette Interface

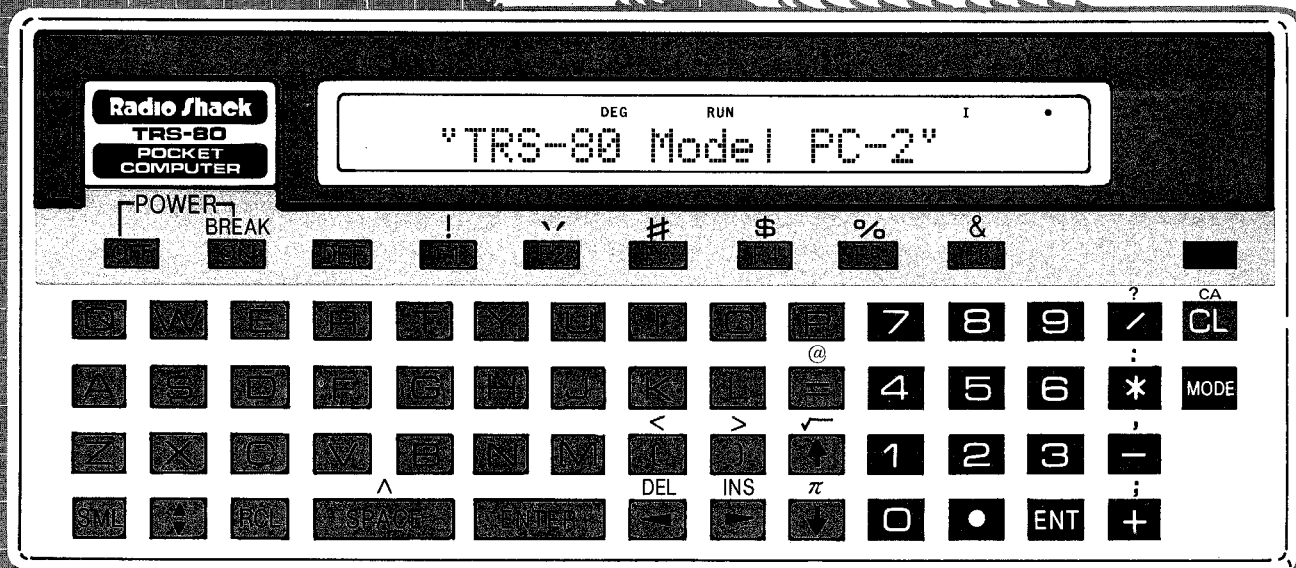

Owner's Manual

cat no 28-3605

TERMS AND CONDITIONS OF SALE AND LICENSE OF RADIO SHACK COMPUTER EQUIPMENT AND SOFTWARE
PURCHASED FROM A RADIO SHACK COMPANY-OWNED COMPUTER CENTER, RETAIL STORE OR FROM A
RADIO SHACK FRANCHISEE OR DEALER AT ITS AUTHORIZED LOCATION

LIMITED WARRANTY

I. CUSTOMER OBLIGATIONS

- A. CUSTOMER assumes full responsibility that this Radio Shack computer hardware purchased (the "Equipment"), and any copies of Radio Shack software included with the Equipment or licensed separately (the "Software") meets the specifications, capacity, capabilities, versatility, and other requirements of CUSTOMER.
- B. CUSTOMER assumes full responsibility for the condition and effectiveness of the operating environment in which the Equipment and Software are to function, and for its installation.

II. RADIO SHACK LIMITED WARRANTIES AND CONDITIONS OF SALE

- A. For a period of ninety (90) calendar days from the date of the Radio Shack sales document received upon purchase of the Equipment, RADIO SHACK warrants to the original CUSTOMER that the Equipment and the medium upon which the Software is stored is free from manufacturing defects. THIS WARRANTY IS ONLY APPLICABLE TO PURCHASES OF RADIO SHACK EQUIPMENT BY THE ORIGINAL CUSTOMER FROM RADIO SHACK COMPANY-OWNED COMPUTER CENTERS, RETAIL STORES AND FROM RADIO SHACK FRANCHISEES AND DEALERS AT ITS AUTHORIZED LOCATION. The warranty is void if the Equipment's case or cabinet has been opened, or if the Equipment or Software has been subjected to improper or abnormal use. If a manufacturing defect is discovered during the stated warranty period, the defective Equipment must be returned to a Radio Shack Computer Center, a Radio Shack retail store, participating Radio Shack franchisee or Radio Shack dealer for repair, along with a copy of the sales document or lease agreement. The original CUSTOMER'S sole and exclusive remedy in the event of a defect is limited to the correction of the defect by repair, replacement, or refund of the purchase price, at RADIO SHACK'S election and sole expense. RADIO SHACK has no obligation to replace or repair expendable items.
- B. RADIO SHACK makes no warranty as to the design, capability, capacity, or suitability for use of the Software, except as provided in this paragraph. Software is licensed on an "AS IS" basis, without warranty. The original CUSTOMER'S exclusive remedy, in the event of a Software manufacturing defect, is its repair or replacement within thirty (30) calendar days of the date of the Radio Shack sales document received upon license of the Software. The defective Software shall be returned to a Radio Shack Computer Center, a Radio Shack retail store, participating Radio Shack franchisee or Radio Shack dealer along with the sales document.
- C. Except as provided herein no employee, agent, franchisee, dealer or other person is authorized to give any warranties of any nature on behalf of RADIO SHACK.
- D. Except as provided herein, **RADIO SHACK MAKES NO WARRANTIES, INCLUDING WARRANTIES OF MERCHANTABILITY OR FITNESS FOR A PARTICULAR PURPOSE.**
- E. Some states do not allow limitations on how long an implied warranty lasts, so the above limitation(s) may not apply to CUSTOMER.

III. LIMITATION OF LIABILITY

- A. EXCEPT AS PROVIDED HEREIN, RADIO SHACK SHALL HAVE NO LIABILITY OR RESPONSIBILITY TO CUSTOMER OR ANY OTHER PERSON OR ENTITY WITH RESPECT TO ANY LIABILITY, LOSS OR DAMAGE CAUSED OR ALLEGED TO BE CAUSED DIRECTLY OR INDIRECTLY BY "EQUIPMENT" OR "SOFTWARE" SOLD, LEASED, LICENSED OR FURNISHED BY RADIO SHACK, INCLUDING, BUT NOT LIMITED TO, ANY INTERRUPTION OF SERVICE, LOSS OF BUSINESS OR ANTICIPATORY PROFITS OR CONSEQUENTIAL DAMAGES RESULTING FROM THE USE OR OPERATION OF THE "EQUIPMENT" OR "SOFTWARE". IN NO EVENT SHALL RADIO SHACK BE LIABLE FOR LOSS OF PROFITS, OR ANY INDIRECT, SPECIAL, OR CONSEQUENTIAL DAMAGES ARISING OUT OF ANY BREACH OF THIS WARRANTY OR IN ANY MANNER ARISING OUT OF OR CONNECTED WITH THE SALE, LEASE, LICENSE, USE OR ANTICIPATED USE OF THE "EQUIPMENT" OR "SOFTWARE".

NOTWITHSTANDING THE ABOVE LIMITATIONS AND WARRANTIES, RADIO SHACK'S LIABILITY HEREUNDER FOR DAMAGES INCURRED BY CUSTOMER OR OTHERS SHALL NOT EXCEED THE AMOUNT PAID BY CUSTOMER FOR THE PARTICULAR "EQUIPMENT" OR "SOFTWARE" INVOLVED.

- B. RADIO SHACK shall not be liable for any damages caused by delay in delivering or furnishing Equipment and/or Software.
- C. No action arising out of any claimed breach of this Warranty or transactions under this Warranty may be brought more than two (2) years after the cause of action has accrued or more than four (4) years after the date of the Radio Shack sales document for the Equipment or Software, whichever first occurs.
- D. Some states do not allow the limitation or exclusion of incidental or consequential damages, so the above limitation(s) or exclusion(s) may not apply to CUSTOMER.

IV. RADIO SHACK SOFTWARE LICENSE

RADIO SHACK grants to CUSTOMER a non-exclusive, paid-up license to use the RADIO SHACK Software on **one** computer, subject to the following provisions:

- A. Except as otherwise provided in this Software License, applicable copyright laws shall apply to the Software.
- B. Title to the medium on which the Software is recorded (cassette and/or diskette) or stored (ROM) is transferred to CUSTOMER, but not title to the Software.
- C. CUSTOMER may use Software on one host computer and access that Software through one or more terminals if the Software permits this function.
- D. CUSTOMER shall not use, make, manufacture, or reproduce copies of Software except for use on **one** computer and as is specifically provided in this Software License. Customer is expressly prohibited from disassembling the Software.
- E. CUSTOMER is permitted to make additional copies of the Software **only** for backup or archival purposes or if additional copies are required in the operation of **one** computer with the Software, but only to the extent the Software allows a backup copy to be made. However, for TRSDOS Software, CUSTOMER is permitted to make a limited number of additional copies for CUSTOMER'S own use.
- F. CUSTOMER may resell or distribute unmodified copies of the Software provided CUSTOMER has purchased one copy of the Software for each one sold or distributed. The provisions of this Software License shall also be applicable to third parties receiving copies of the Software from CUSTOMER.
- G. All copyright notices shall be retained on all copies of the Software.

V. APPLICABILITY OF WARRANTY

- A. The terms and conditions of this Warranty are applicable as between RADIO SHACK and CUSTOMER to either a sale of the Equipment and/or Software License to CUSTOMER or to a transaction whereby RADIO SHACK sells or conveys such Equipment to a third party for lease to CUSTOMER.
- B. The limitations of liability and Warranty provisions herein shall inure to the benefit of RADIO SHACK, the author, owner and/or licensor of the Software and any manufacturer of the Equipment sold by RADIO SHACK.

VI. STATE LAW RIGHTS

The warranties granted herein give the **original** CUSTOMER specific legal rights, and the **original** CUSTOMER may have other rights which vary from state to state.

Contents

	Page
Introduction	2
1/Description of the Printer/Cassette Interface	3
2/Setting Up the Printer/Cassette Interface	9
Connection Paper Installation Pen Installation Power Supply	
3/Using the Printer/Cassette Interface	29
Cassette Recorder Operation Cassette Commands Plotter/Printer Operation	
Printer Commands	
4/Care and Maintenance	101
5/Specifications	105
Appendix A/Language Reference Summary	107
Appendix B/Error Codes	111

Introduction

Congratulations on your selection of the TRS-80 Pocket Computer (Model PC-2) Printer/ Cassette Interface! You'll find this Interface a useful addition to your already powerful PC-2.

With your Plotter/Printer, you can print copies of your programs and data and even plot graphic displays.

With your Interface, you can store and retrieve your programs and data on cassette. (Optional recorders are required. We suggest the Miniset-9, Radio Shack Catalog Number 14-812.)

Special features of the Interface include:

- Easy-to-read printouts on plain paper.
- Graphic printing in four colors.
- Convenient to use — you can display your output on the Computer's display or Plotter/Printer (or both)!
- Paper Advance Button and paper-cutting edge for easy paper advancement and separation.
- Battery powered for fully portable operation — you can use your Computer and Interface anywhere!
- External power supply to operate and recharge your Interface.
- Two-Recorder Option lets you connect the Interface to two recorders — spending less time swapping cassettes. You can have one cassette for "reading" and one for "writing".
- Remote Switch allows for manual or Computer control of the cassette recorders.
- Print Switch gives you a "no-print" option, letting you display your calculations on PC-2's display without a printout.
- One-button power — once you turn the Computer ON, the Interface is also turned ON.
- Character size specification that lets you set the size of the printing character to suit your printing needs.

1/Description of the Printer/Cassette Interface

Your Interface package includes:

- The Printer/Cassette Interface
- Two Cassette Recorder Cables
- Three rolls of printing paper
- AC adapter
- Four pens (black, blue, green, and red)

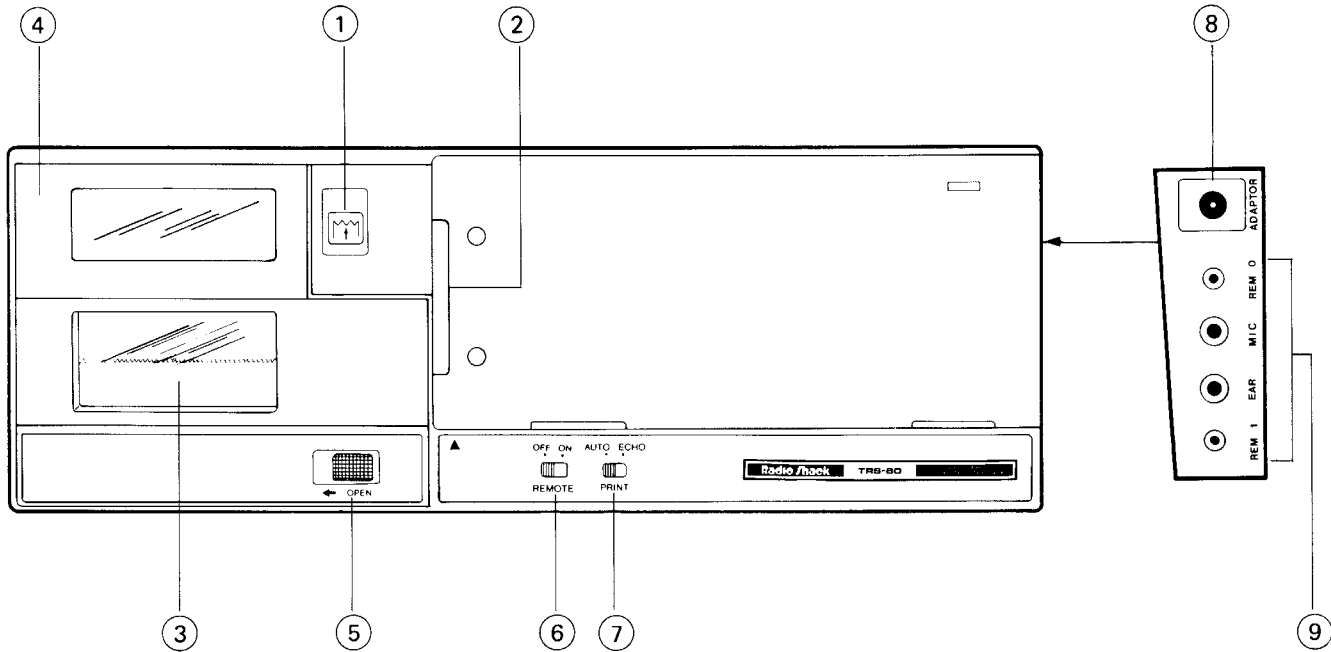







Figure 1. Printer/Cassette Interface (Front View)

- (1) **Paper Feed Button** Advances paper through the platen. Holding  and the  button down simultaneously puts the Printer into Pen Replacement Mode (a special mode for installing and removing the pens). Holding  and the  button down simultaneously clears the Pen Replacement Mode and returns the unit to normal operation.
- (2) **Computer Connection Terminal** Connects the Interface to your Computer.
- (3) **Printer** Body of Plotter/Printer.
- (4) **Printer Cover** Encloses paper, pens, and printing area.
- (5) **Printer Cover Lock** Locks the Printer Cover in place. Slide the lock to the left to remove the Printer Cover.
- (6) **Remote Switch** With the switch set to ON, the Computer controls the start and stop of the Cassette Recorder. With the switch in the OFF position, you can operate the Cassette Recorder manually.
- (7) **Print Switch** Sets Print condition of Printer. The switch can be set to either AUTO (information is only displayed on your Computer's Display) or ECHO (information is displayed on the Display and printed on the paper).
- (8) **AC Adapter Jack** Connects the AC adapter to your Interface.
- (9) **Cassette Recorder Jack** Connects the Cassette Recorder(s) to your Interface.

Note: The Interface does not have a power switch. The Power Switch of the PC-2 turns the Interface ON and OFF. The Interface is turned OFF when disconnected from the Computer. Your PC-2 must be turned ON if you want to use any part of the Interface (including the  button).

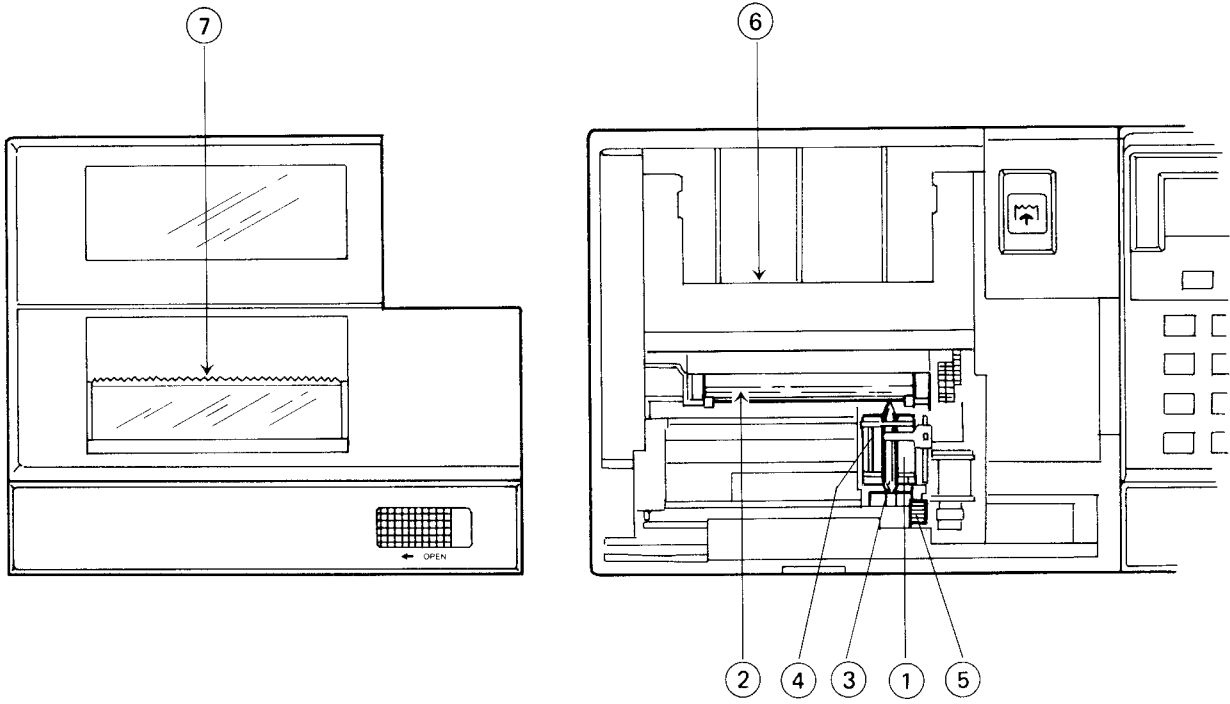

Figure 2. Printer

- (1) **Pen Holder** Holds four pens and is the printing “head” of your Plotter/Printer. Rotates to different colors.
- (2) **Platen** Moves to help feed paper.
- (3) **Pens** Water-color pens for multi-color plotting/printing.
- (4) **Pen Positioning Indicator** Identifies Pen Position #0 as the first position to the right of the Indicator.
- (5) **Pen Remove Lever** White plastic lever releases the pens for installation, storage or replacement.
- (6) **Paper-In** Slot for inserting the leading edge of paper with installing a paper roll.
- (7) **Paper Cutter** Serrated edge for cutting printouts.

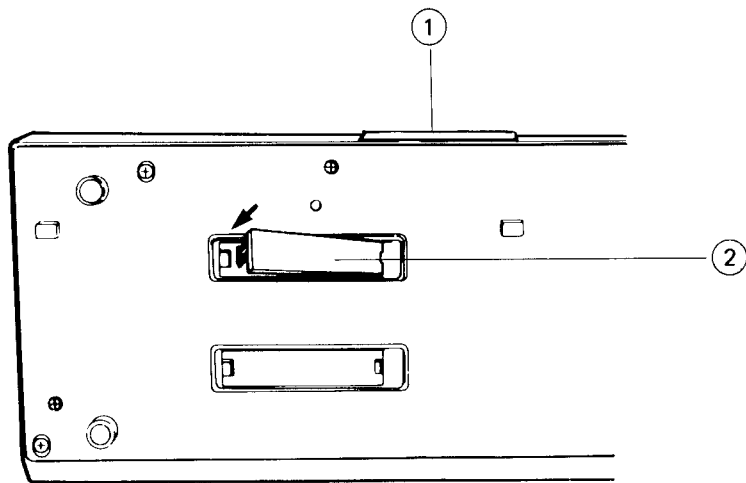

Figure 3. Interface (Rear View)

- (1) **I/O Channel** For use with other optional peripherals.
- (2) **Interface Cover Holders** Conveniently stores each of your Interface Covers (one cover fits over PC-2's Interface and the other fits over the I/O Channel on the Printer/Cassette Interface).

2/Setting Up the Printer/Cassette Interface

Connecting the Interface to the Computer

The Interface and PC-2 are designed for easy connection to each other. To connect, the Computer's power must be OFF. If the power is ON when you connect the Interface, the Computer may "hang up" (all keys inoperative). If this happens, turn the Computer's power OFF, disconnect the Computer from the Interface, turn the Computer over and with the **(ON)** key held down, press the ALL RESET button (on the bottom of the Computer) for approximately 15 seconds.

It is extremely important that you do not force the Interface and Computer together or you may damage the Interface, the Computer or both.

Follow this procedure when connecting the Interface to the PC-2:

1. Turn the Computer's power OFF.
2. Remove the Terminal Cover from the left side of the Computer and snap it into place on the bottom of the Interface.

3. Place the lower edge of the Computer downward so that the "Printer Guides" match-up with the Computer's "Guide-Slots." (The keyboard should be facing upward.)

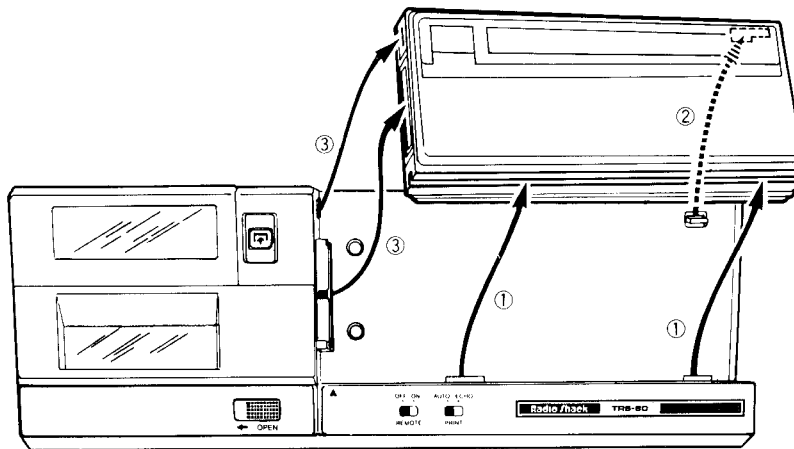

Figure 4. Computer-Interface Alignment

4. Lay the Computer down flat.
5. Gently slide the Computer to the left so the Interface pins are inserted into the Computer. Align the side of your Computer closely with the Interface as you slide to the left.

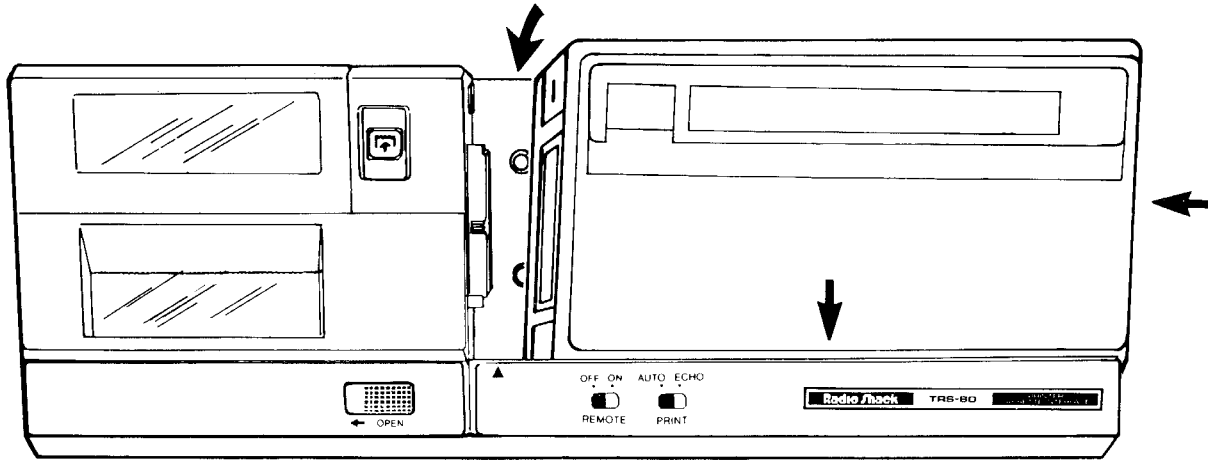

Figure 5. Connection to Interface Terminal

Do not force the Computer and Printer together. If match-up does not easily take place, carefully shift the Computer left and then right to correctly position the connecting surfaces together.

To Remove the Computer, follow this procedure:

- (1) Turn the Computer OFF and remove the Printer Cover.
- (2) Remove the Computer by grasping the edge of the Computer and moving the Computer to the right.

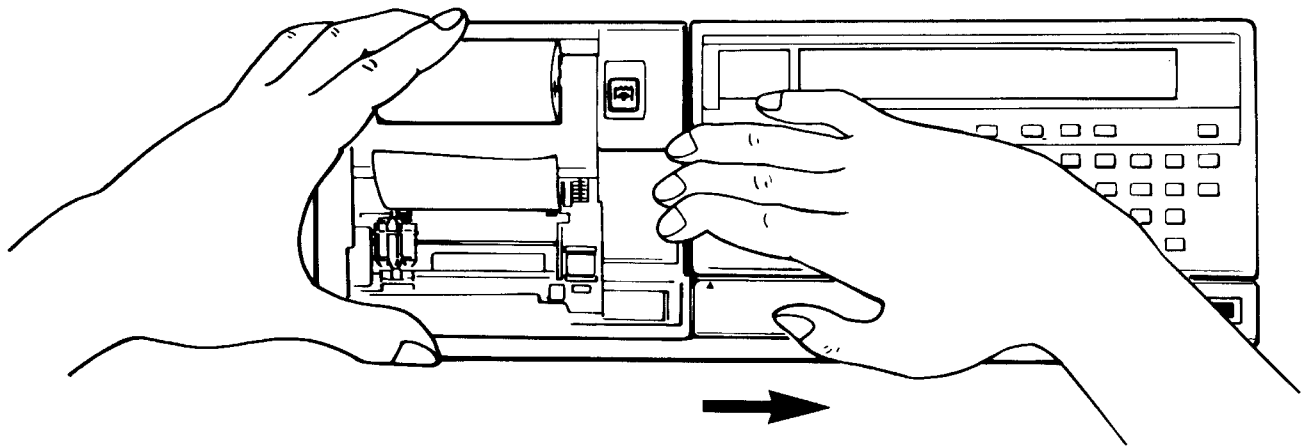

Figure 6. Removing the PC-2 from the Interface

Installing the Paper

Three rolls of paper are included with your Interface.

Important Note: The Printer's paper is extremely sensitive to oil from your hands. Try to avoid touching the paper as much as possible — even light contact can cause oily discoloration which can distort the quality of printing. When loading paper, hold the paper on the sides with the side of your fingers so there is minimum contact.

Follow this procedure for loading the paper:

1. Be sure your Computer is connected to your Interface and is turned ON (remember, the PC-2 controls the power of the Interface). Shift the Printer Cover Lock to the left, then remove the Printer Cover.
2. Tighten the roll of paper by holding the roll in your hand and pulling on the leading edge of the paper.
3. Cut the end of the roll of paper evenly.
4. Gently insert the edge into the Paper Inlet. (Any curve or crease on the leading edge of the paper may prevent proper paper feeding or cause paper jamming.)

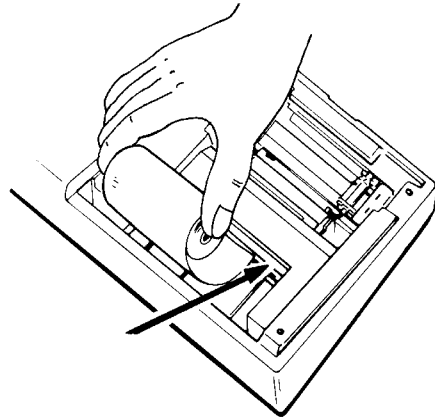



Figure 7. Inserting Paper

5. To advance the paper, use the  button on the Printer. By holding this button down, the paper is fed through the Printer's platen.

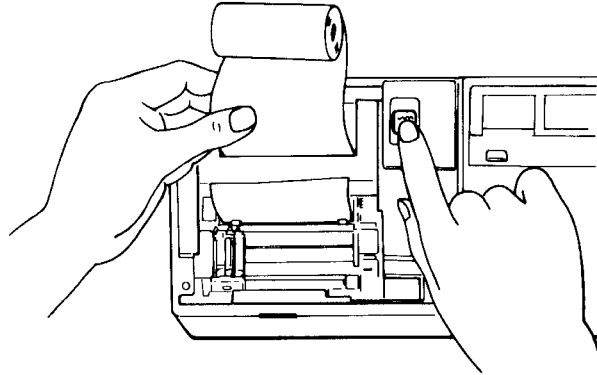

Figure 8. Feeding Paper

6. The Paper Holder Spindle is located in the Paper Case area (in the upper left corner of the Interface where the paper is held). Remove the Paper Holder Spindle and insert the shaft into the roll of paper. Insert the roll of paper into the Paper Case.

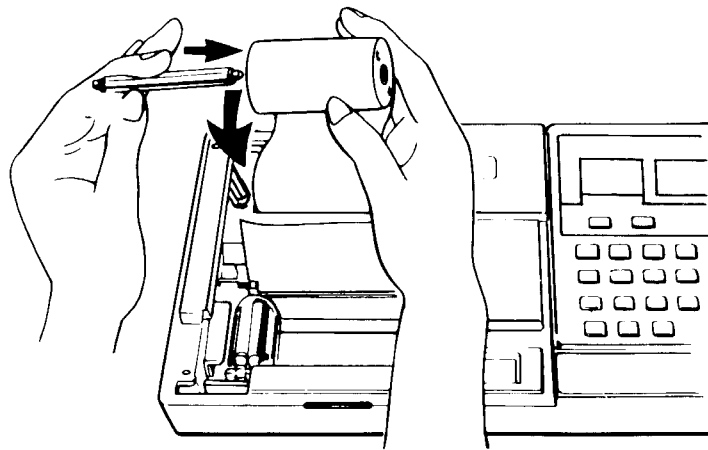



Figure 9. Inserting Roll of Paper into Paper Case

7. Place the Printer Cover back in position. Hold down the  button to thread the paper through the Paper Cutter. Lock the Printer Cover by sliding the Printer Cover Lock to the right.

Installing and Removing the Pens

Your Interface comes with four pens: black, blue, green, and red. The pens must be installed in the Pen Holder before you can begin printing.

Important Note: You must always use four pens. Using the Printer with only three (or fewer) pens may cause incorrect color changes when you are changing color (see Printer Commands, COLOR).

Install the pens when you want to use the Printer and remove them after printing. Cap the pens and place them in their cases when you're not using them or the ink may dry out. Replace the pens when they dry out.

Quick-Tip: If the pens begin to dry out, remove them, dip each tip lightly into a drop of water and insert the pens back into the Pen Holder.

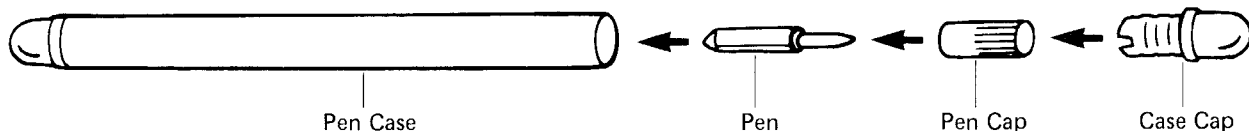

Figure 10. Pen Assembly

When installed, the pens are held in a circular Pen Holder. The Pen Holder rotates during printing to access different Pen Positions (and hence, different colors).

Turn the PC-2 ON. When the Computer is turned ON (if you previously manually turned it OFF as opposed to automatic shut-OFF), the Pen Holder rotates Pen Position #0 to the printing position. From this position, the Pen Positions (#0, #1, #2, and #3) are numbered clockwise (with the "clock" facing you — #0 position is "12 o'clock," #1 position is "3 o'clock," #2 position is "6 o'clock," and #3 position is "9 o'clock.")

You install and remove pens by entering a special pen-changing state called the Pen Replacement Mode. To enter this mode, press **O** and the **↕** button. To exit the mode, press **CL** and the **↕** button.

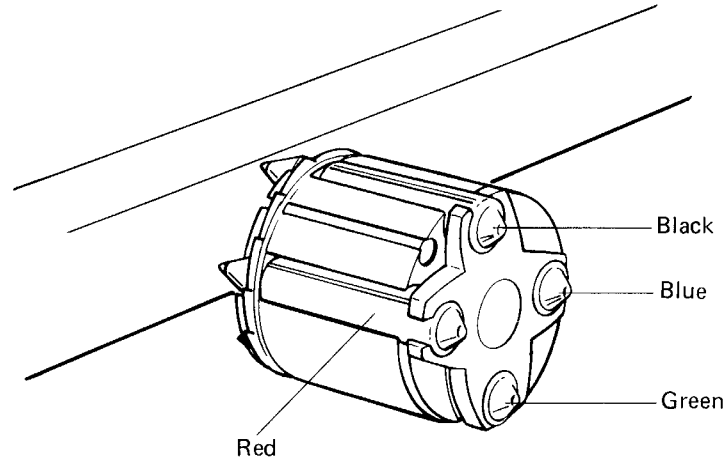

Figure 11. Pen Holder

Look at the Pen Holder and you'll see a four-color disk on the inside hub of the holder (next to the platen). This is the Pen Color Disk. Each quarter of the Pen Color Disk is color-coded clockwise: black, blue, green, and red. (This is also the alphabetical order of the colors.):

It's very convenient to install the pens according to the Pen Color Disk; however, you can install the pens in any order you want. In this manual, we'll refer to the pen positions and pen colors according to the Pen Color Disk: black, blue, green, and red.

Here's an easy way of installing the pens and remembering the position of each color:

- Install each pen according to the color's on the Pen Color Disk.
- Install the black pen in the black position, blue pen in the blue position, green pen in the green position, and the red pen in the red position.

Now look again at the Pen Holder and you'll see a thin, metal strip. This is the Pen Position Indicator which identifies the Pen Position #0 as the first pen position to the right. If you prefer, you can install the pens according to their position from the Pen Position Indicator:

- The position to the right of the Pen Position Indicator is #0. As we mentioned before, on power-up, the Pen Holder rotates Pen Position #0 to the printing position. (Note: The Pen Holder does not rotate after the Computer has automatically turned itself OFF.)
- Install the black pen in Position #0, then install the other three pens clockwise in this order: blue (#1), green (#2), and red (#3).

All pens will probably not have to be changed at the same time, depending on your use. Two three-pen packs: all black (Cat. No. 26-1480) and multi-colored (red, green, and blue, Cat. No. 26-1481) are available at your Radio Shack Computer Center. These pens are specifically designed for your Printer; using any other pens may damage the Printer.

Follow this procedure when replacing or removing the pens:

1. Press and hold the Computer's **O** key and then press the **↕** button. Release both and the Pen Holder will shift to the right and stop. It is now in the Pen Replacement Mode. Release **O** and the **↕** button.
2. Decide which pen you want to replace. If the pen is not on top, press the **↕** button again. The Pen Holder will move back to the left side of the printing area and will rotate counterclockwise to the next pen position, then return to the right side. Repeat the procedure until the pen you want to replace is on top.
3. To remove the pen, gently press the white plastic Pen Removal Lever (in the lower right corner of the Printing Area) towards you. This causes the pen on top to slip out. Note: Be sure to gently press the Removal Lever. If you forcefully press the lever, the pen may pop out and, because of the pen's small size, you may have a hard time locating it.
4. Remove the pen from the Pen Holder area, holding it gently to prevent the pen from falling into the Printer.

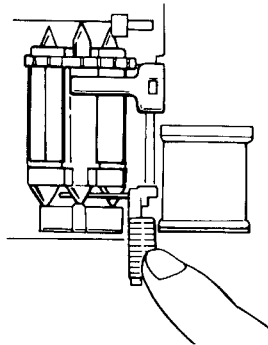





Figure 12. Pen Removal Lever

5. Install a new pen by inserting the pen tip into the printing hole at the top of the Pen Holder. Slide the other end of the pen until the pen snaps into place.
6. To install or remove the next pen, press the  button momentarily. The Pen Holder returns to the left, rotates so that the next pen comes on top and shifts to the right again. Remove the pen and replace it with a new one.
7. After the pen replacement or installation, press  and the  button. (Note: Be sure to press  first.) This causes the Printer to leave the Pen Replacement Mode and the Pen Holder to move to the left. The Pen Holder is now ready for printing.

Connecting a Cassette Recorder to the Interface

There are two cables supplied with your Interface:

- A two-plug black cable with one plug on each end.
- A six-plug multi-color cable with three plugs on each end.

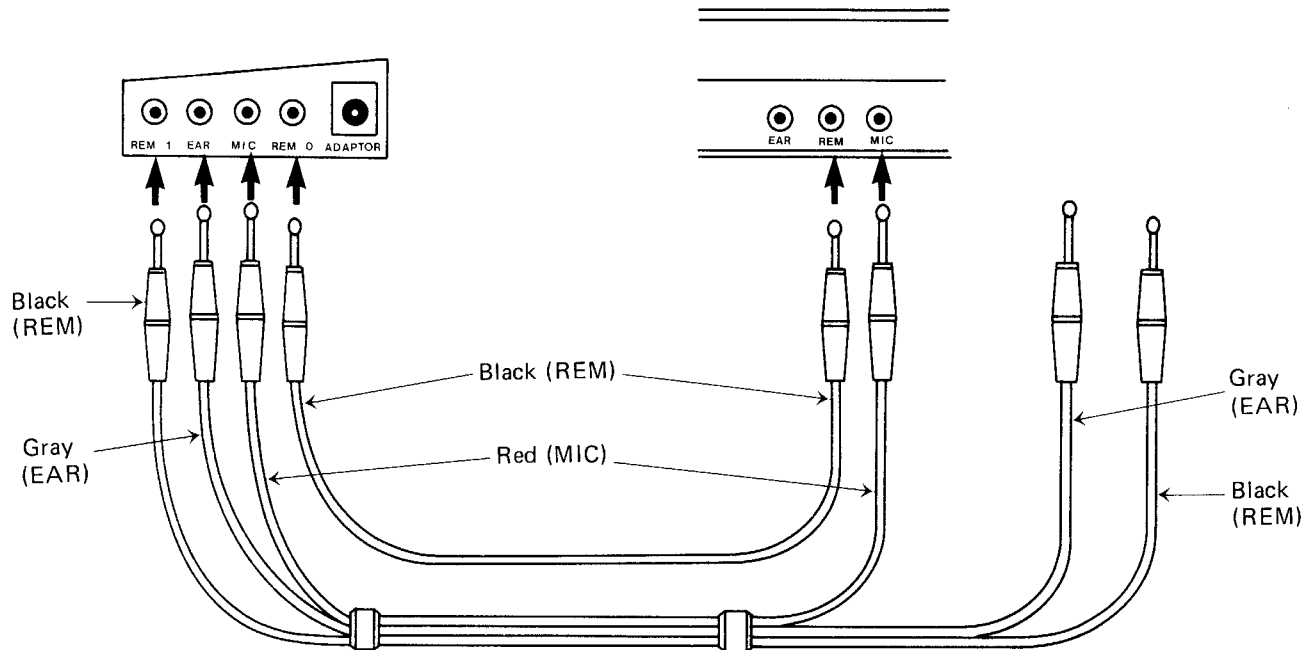

Figure 13. Cassette Cables and Interface Jacks

The six-plug cable has three plugs on each end — one black (REM), one red (MIC), one gray (EAR). There are three jacks on the Cassette Recorder: EAR, MIC, and REM. There are five jacks on the Interface: REM 1, EAR, MIC, REM 0, and ADAPTOR. REM 0 is for the first Cassette Recorder and REM 1 is for the second Cassette Recorder.

If you are using one Recorder, you will use all three of these jacks. The black cable which has a plug on each end is for REMOTE jacks (one for the Interface and one for the second Cassette Recorder).

If you are not familiar with Cassette Recorders, the following hints may help you set up your two-recorder system:

- Think of "EAR" (earphone) as output from the Cassette Recorder, like an earphone jack and gray plug.
- Think of "MIC" (microphone) as input to the Cassette Recorder, like a recording microphone or speaker and the red plug as RECORD.

To connect one recorder . . .

1. Plug one end of the six-plug cable into your Interface.
2. Plug the other end of the cable into your recorder.
3. On the Interface, insert the gray plug into EAR jack, the red plug into the MIC jack, and the black plug into the REM 0 jack. On the Cassette Recorder, the plugs' jacks must match the Interface's (i.e., if you inserted the red plug into the MIC jack on the Interface, you must insert the red plug into the MIC jack on the Cassette Recorder).

To connect two recorders . . .

With two recorders, you use either the EAR jack of one recorder or the MIC jack of the other recorder (depending which recorder is for reading and which is for writing). You'll use the REM jack (black plugs) with both Cassette Recorders.

1. Take one end of the six-plug cable and connect two of the plugs (one black and one red or gray) to the REM 0 jack and MIC or EAR jack of the first recorder and to the REM 0 jack and MIC or EAR jack on the Interface.
2. Take the other plug (the remaining red or gray plug) and connect to the MIC or EAR jack on the second recorder and to the MIC or EAR jack on the Interface.
3. Take the black cable (which has just one plug on each end) and connect one plug into the REM jack of the second recorder and into the REM 1 jack on the Interface. Now both recorders should be connected to one black plug and one red or gray plug (two plugs in each recorder). Four plugs should now be in the four jacks on the Interface.

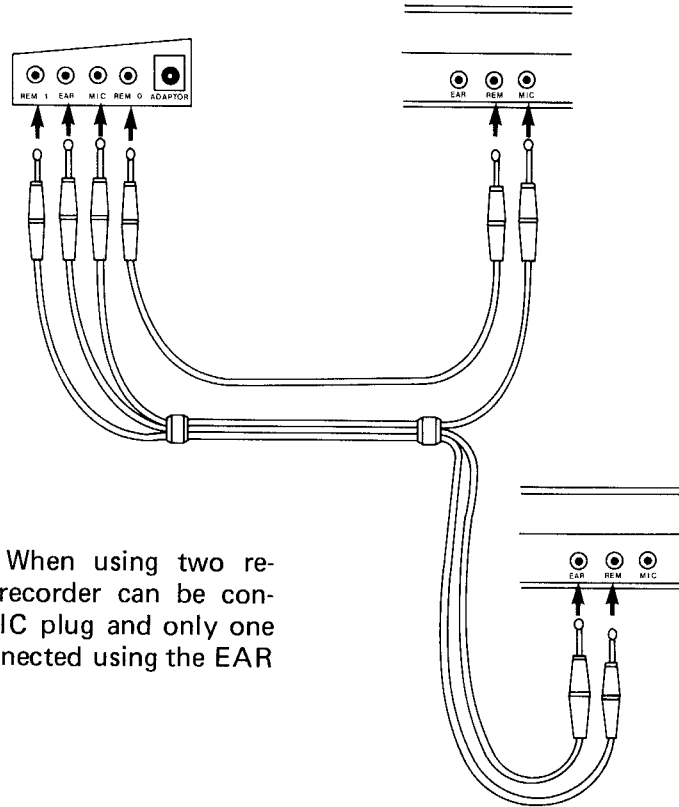

Important Note: When using two recorders, only one recorder can be connected using the MIC plug and only one recorder can be connected using the EAR plug.

Figure 14. Connecting Cable to Two Recorders

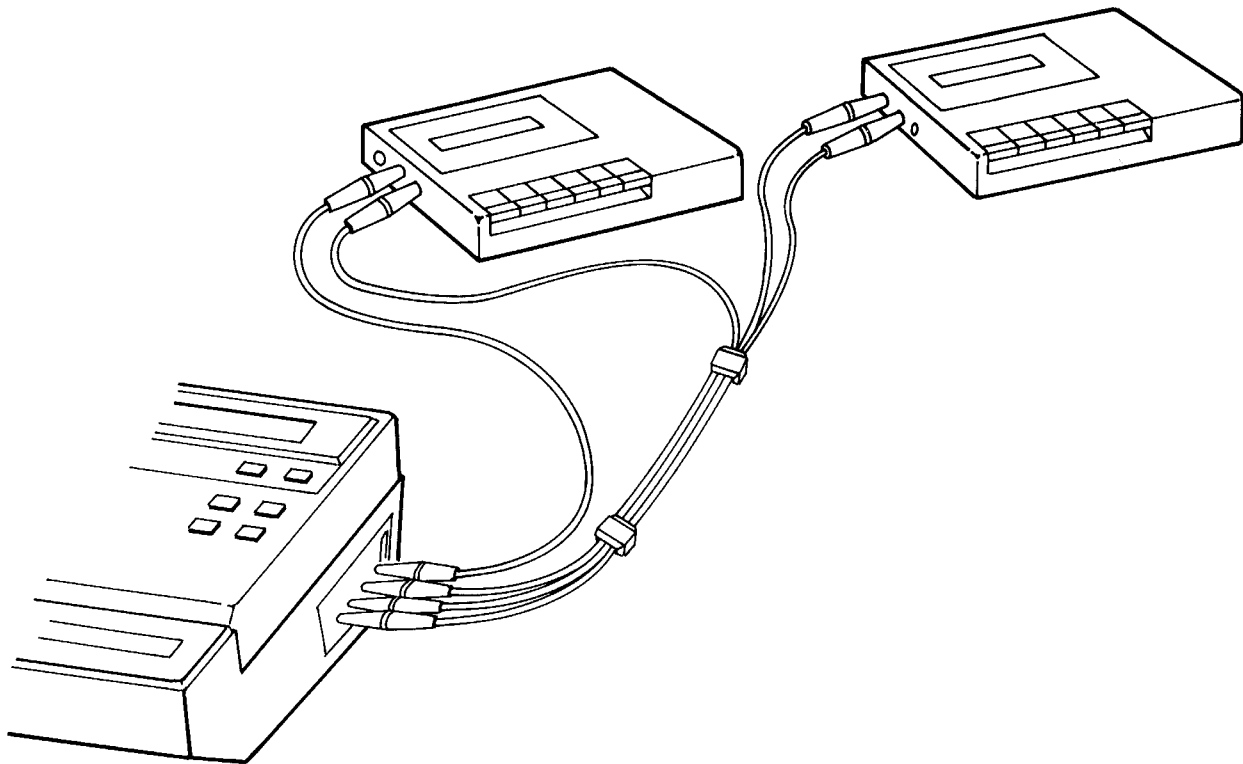

Figure 15. Recorders Connected to Interface

Dummy Plug

Normally, a Dummy Plug is included with your Cassette Recorder. You can use this plug when you want to erase all or a part of your cassette. This plug works by blocking information from entering the Cassette Recorder's built-in microphone as you erase. If you do not have a built-in microphone on your cassette recorder, you don't need to use this plug.

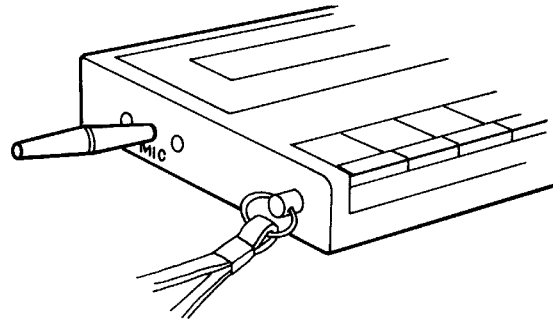

Figure 16. Dummy Plug

To use the Dummy Plug, follow this procedure:

1. Place your cassette in the Cassette Recorder and insert the Plug into the recorder's MIC jack.
2. Rewind the tape to the position where you want to start erasing. Operate your recorder as though you are recording. As the cassette moves, it will be erased.
3. Stop the recorder where you want to stop erasing. Advance the recorder to other segments you want to erase (if any) and repeat the above procedure.

For details on using the Cassette Recorder once it is connected, see Using the Printer/Cassette Interface.

Printer Power Supply

Your Printer is powered by an internal rechargeable Nickel-Cadmium (Ni-Cd) battery pack.

It may be necessary to recharge the battery with the AC adapter before you use the Printer for the first time. If you don't use your Printer for three or more months, you'll probably need to recharge the battery.

Important Note: Be sure to use the AC adapter supplied with your Printer when recharging your Interface. Any other adapter may damage your unit.

To recharge the battery:

1. Turn the Computer's power OFF.
2. Plug the adapter into a wall outlet.
3. Connect the AC adapter to the Interface.

To remove the adapter:

1. Turn the Computer's power OFF.
2. Disconnect the AC adapter from the Interface.
3. Remove the adapter from the wall outlet.

Important Note: To avoid damage to the Interface, be sure to always plug the adapter in the outlet before connecting the adapter to the Interface. Also, disconnect the Interface before unplugging the adapter.

It will take about 15 hours for the battery to become fully charged. Note: We recommend that, whenever possible, you use the Interface with the AC adapter. The Interface will run down slowly (after about 15 hours of steady use) even with the AC adapter plugged in.

Note: If you don't use your Interface for a long time, the battery may lose power. If this happens, a 15-hour recharge will not be long enough to fully charge the battery. A slightly longer recharging is needed to make the Interface fully charged.

Unless you are using the AC adapter, do not use the Interface with the battery only partially charged. For best results, fully charge the battery before each use.

When the Printer is connected to the Pocket Computer and the battery is low, you will get a low-battery error (ERROR 78, 80, CHECK 6). The errors will be displayed immediately when the PC-2 is turned ON if the batteries are low. See Appendix B, Error Messages, for descriptions of these errors.

The battery pack is long-life but may eventually fail to charge and need to be replaced. If you suspect a problem, take your Interface and adapter to your Radio Shack Computer Center. The battery pack is wired into the Interface and must be replaced by Radio Shack personnel.

3/Using the Printer/Cassette Interface

Cassette Recorder Operation

You can use your Cassette Recorder for two purposes:

- Transferring data and programs from your cassette to your PC-2.
- Transferring data and programs from your PC-2 to your cassette.

Follow these steps to prepare your recorder (s) for saving data and program:

1. Set the Remote Switch on the Interface to OFF and put a cassette in your recorder.
2. If the cassette is fully rewound, advance the cassette past the "leader" portion. (You might find "leaderless" cassettes more convenient to use. We suggest Radio Shack's C-20 Certified Leaderless Cassettes, Cat. No. 26-301). If your cassette is new and leaderless, you can start saving programs at the beginning of your cassette is not new, find a blank portion of the cassette.
3. Set the Cassette Recorder's volume control according to your owner's manual. (Note: Most Cassette Recorders have automatic control of the recording volume. In these recorders, volume control only pertains during playback.)

4. Set the Remote Switch on the Interface to ON.
5. Press both the RECORD and PLAY buttons on your Cassette Recorder simultaneously. You are now ready to save your program or data.

It is a good idea to save each of your programs at least twice, preferably on separate cassettes. That way, if one cassette is lost or erased, you have an extra copy.

When you want to load the program, you can specify the file name and your Computer searches for the filename. If you prefer, you can omit the filename and your Computer loads the first program it finds on the cassette.

If you use a filename longer than 16 characters, the excess characters are ignored. For instance: "ARCHITECTUREPROGRAM" is saved as: "ARCHITECTUREPROG"

Remote Switch and Command

If you use two Cassette Recorders with your Interface, you will connect Cassette Recorder #1 to the Remote 0 jack and Cassette Recorder #2 to the Remote 1 jack.

Keep the Remote Switch to the ON position whenever you want the PC-2 to control the cassette in Cassette Recorder #1 (Remote 0). If the switch is ON, the cassette will start when you save or load a program or data and stop when the operation is complete.

If you want to start or stop Cassette Recorder #1 manually, you'll use the RMT control with the Remote Switch. This lets you access Cassette Recorder #1 (Remote 0) without removing the black plug from the REM jack on the recorder.

To operate Cassette Recorder #2 (Remote 1), use one of the two Remote Commands: RMT OFF (allows manual control) or RMT ON (allows program control). Type:

RMT OFF **ENTER**

or

RMT ON **ENTER**

(Note: These commands only affects Remote1.)

RMT ON starts the RMT control. RMT OFF cancels the RMT control and lets you manually control the Cassette Recorders.

RMT OFF abbreviations are: RM.OF. RMTOF.

RMT ON abbreviations are: RM.O. RMTO.

Through you program statements, you can access the Cassette Recorder (cassette #2) connected to the REM 1 jack by appending "--1" onto your program statement:

INPUT#-1

This peripheral specifier works by telling PC-2 to access the peripheral device (in this case, the Cassette Recorder) connected to the REM 1 jack. There are three different procedures you can use with using "--1":

1. Saving
2. Comparing PC-2's memory with cassette
3. Transferring program or data file from cassette

To save a program or data file on cassette #2:

1. Type:

```
RMT OFF ENTER
```

to turn OFF the RMT control.

2. Put a cassette into Cassette Recorder #2 (connected to the REM 1 jack).
3. Type RMT ON and press **ENTER** to turn ON the RMT control function.
4. Press the PLAY and RECORD buttons and enter the PRO or RUN mode.
5. For a program file ("PROGRAM" represents the filename of the program), type:

```
CSAVE-1"PROGRAM" ENTER
```

For a data file, type:

```
PRINT#-1, "PROGRAM";A, B . . . ENTER
```

6. Enter either the PRO or RUN mode and type:

```
CSAVE-1"PR-1" ENTER
```

Comparing PC-2's memory with a file on cassette #2:

1. Type:

```
RMT OFF (ENTER)
```

to turn OFF the RMT control.

2. Rewind the cassette.

3. Enter RMT ON (ENTER) to turn ON the RMT control.

4. Press the PLAY button and enter the PRO or RUN mode.

5. Type ("PROGRAM" represents the filename of the program):

```
LOAD?-1 "PROGRAM" (ENTER)
```

6. Execution ends when both contents match and PC-2's prompt is displayed.

Transferring a program or data file from cassette #2:

1. Type:

```
RMT OFF (ENTER)
```

to turn OFF the RMT control.

2. Put the cassette that contains the file into Cassette Recorder #2 (REM 1).

3. Type:

```
RMT ON (ENTER)
```

to turn ON the RMT control.

4. Press the PLAY button and enter the PRO or RUN mode.

5. For a program file, type ("PROGRAM" represents the filename of the program):

```
CLOAD-1 "PROGRAM" (ENTER)
```

For a data file, type:

```
INPUT#-1, "PROGRAM":A,B . . . (ENTER)
```

6. After the transfer, PC-2's prompt is displayed.

Cassette Commands

Table 1 lists the cassette commands that are recognized by the Interface.

Commands	Function
CHAIN	Loads program segment and executes
CLOAD	Loads program from cassette
CLOAD?	Verifies cassette program with program in memory
CSAVE	Saves programs to cassette
INPUT#	Transfers data from cassette to Computer
MERGE	Appends two programs in memory
PRINT#	Transfers data from Computer to cassette
RMT ON/ RMT OFF	Allows manual operation of cassette #2 (Remote 1)

Table 1

CHAIN

Loads Program Segments and Executes

CHAIN-1 "*filename*", *line number*

–1 is the optional peripheral specification and specifies REM 1.

filename is the name of your program and must be 16 alphanumeric characters or less; optional, if omitted, the first program is loaded.

line number is a five character or less expression from 1-65279 decimal and specifies the beginning line for program execution; optional, if omitted, program execution starts at the lowest line number.

Abbreviations: CHA. CHAI.

A CHAIN statement lets you run a program that is too large to fit into memory all at one time. By dividing the program into segments and saving each segment to cassette, you can use the CHAIN statement to load each segment and immediately execute the program (without having to enter RUN).

The main advantages of CHAINing segments of programs together is:

- CHAIN permits consecutive execution of related programs automatically without needing to keep more than one of them actually in the PC-2's memory at a given time.
- CHAIN saves you time because it automatically loads segments and run the program without you having to type: RUN
- All the variable from the program (the one before the CHAIN command) are preserved.

Special Notes about CHAIN:

- The CHAIN instruction can only be used within a program. CHAIN cannot be used manually like CSAVE, CLOAD, and MERGE.
- If a filename you specify is not on the cassette, PC-2 continues to search for the absent filename even after the cassette has come to an end.
- Remember to save each sequential program segment with a sequentially numbered filename (i.e., PROGRAM1, PROGRAM2, PROGRAM3, etc.).

To use CHAIN:

1. As you write a large program, decide where you want to segment the program and save the respective segments on cassette under their respective filenames. Each segment (except for the last) has to have a CHAIN statement as the last program line.
2. Rewind the Cassette Recorder to PLAY.
3. When you are ready to run the program, enter the CHAIN statement and filename into a program line. The CHAIN statement then automatically loads and executes the each consecutive segment until all the segments are executed.

Example

Let's say we have written a large program for your PC-2 which you have divided into three segments, each of which fits into PC-2's memory.

You have saved the three program segments (SALE1, SALES2, and SALES3) on cassette and the program segments SALES1 and SALES2 have CHAIN statements at the place in the program segment where the next segment is to be loaded.

When each CHAIN statement is encountered, the file you have specified is located on cassette and read into the PC-2. The segment is automatically RUN beginning at the lowest line number or the line number specified in the CHAIN statement. All variables from the program before the CHAIN statement are saved for the program being CHAINED in memory.

"SALES1"

10: PROGRAM LINE

.

.

.

.

500: IF A = B CHAIN "SALES2"

.

.

.

.

.

.

.

1000

"SALES 2"

1010: PROGRAM LINE

.

.

.

.

.

.

.

2000: CHAIN "SALES3", 3000

Segment I
(SALES1)

Program lines 10
through 990

Segment II
(SALES2)

Program lines 1020
1990

"SALES 3"

2010: PROGRAM LINE

.

3000: PROGRAM LINE

.

4000: END

Program lines 2010
through 3990

Segment III
(SALES3)

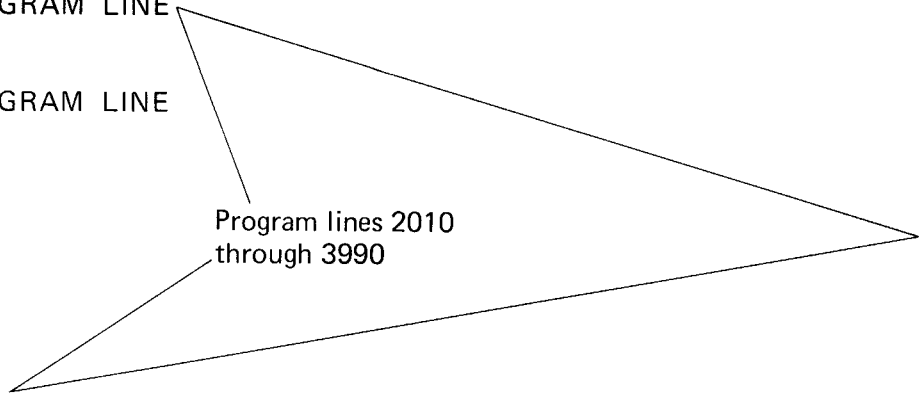

When you run the program, your computer encounters the CHAIN statement, calls the next program segment into memory and executes it. In this manner, all of the segments are eventually run.

CLOAD?

Compares Cassette Program with Resident Program

CLOAD?-1 "filename"

–1 is the peripheral specification and specifies REM 1.

filename is the name of your program and must be 16 alphanumeric characters or less; *filename* is optional; if omitted, the first filename encountered is used.

Abbreviations: CLO.? CLOA.?

Important Note: CLOAD? is for verifying a saved program file only and cannot verify a saved data file.

CLOAD? checks whether the program you have saved on cassette is the same as the program in the Computer's memory. PC-2 displays the filename it finds when reading the cassette.

If the program is correctly saved, PC-2's prompt is displayed following verifications.

If there is an error, an error message will be displayed (ERROR 43 is common). ERROR 43 means the program on cassette is different from the program in your Computer's memory. If you get an error, try rewinding the cassette, adjusting the volume setting, checking all connections and trying again.

Special Notes about CLOAD?:

- Use CLOAD? from either the RUN, PRO, or RESERVE modes.
- When there is nothing in memory and the CLOAD? statement is used, ERROR 43 will occur.
- If you specify a filename and it is not on the cassette, PC-2 will continue to search for the absent filename even after the cassette has come to an end.

Examples

```
CLOAD?"PROG"
```

Searches for program "PROG" on Cassette Recorder #1. When the program is found, the filename is displayed on PC-2's screen and PC-2 compares this program with what is in memory.

CLOAD

Loads Program from Cassette

```
CLOAD-1 "filename"
```

-1 is the peripheral specification and specifies REM 1.

filename is the name of your program and must be 16 alphanumeric characters or less. *filename* is optional; if omitted, the first file encountered is loaded.

Abbreviations: CLO. CLOD.

You can use CLOAD in any of three different modes — RUN, PRO, or RESERVE.

Special Notes about CLOAD:

- Your PC-2 cannot decide whether a certain filename refers to a regular program file (RUN or PRO) or a reserve program file. Therefore, an improper mode selection (PRO mode for a reserve program instead of RESERVE mode) leads to an improper transfer: reserve files to the Computer's main memory or regular cassette files to

the reserve memory. Each time you load a file, be sure you are not in the RESERVE mode unless you are loading a reserve file. When CLOAD is used in the RESERVE mode, the file is loaded as defined key data.

- If a file you want to load is not on the cassette, PC-2 will continue to search for the missing file even after the cassette has come to its physical end. (In this case, cancel the instruction by pressing **(BREAK)** .)
- If an error is encountered during the transfer of programs, only the program memory is cleared. If there is an error, an error message will be displayed.

Follow these steps when loading a program from cassette:

1. Set the Remote Switch on the Interface to OFF.
2. Rewind the cassette to the place where your program is located.
3. Stop rewinding.
4. Set the Remote Switch to ON.
5. Press the PLAY button on your recorder. (Check to make sure you are not in the RESERVE mode unless you are loading a reserve file.)
6. Type: `CLOAD"filename" (ENTER)`

BUSY is displayed on the PC-2 and as soon as the file is found, the name is displayed on the screen. The program is then loaded into your Computer's memory. Here is an example for a file named "PROG".



When the file is loaded, PC-2's prompt appears on the screen. You can now run the program (Type: RUN **ENTER**). Even though the program is in your Computer's memory, it is still on your cassette, so you can CLOAD the program over and over again.

You can use CLOAD in the RUN, PRO, or RESERVE modes. Use the RESERVE mode when you are loading reserve programs.

Example

```
CLOAD"PROFIT"
```

Searches for program "PROFIT". When the program is found, it is loaded into memory.

```
CLOAD-1"PROFIT"
```

Searches for program "PROFIT" on Remote 1 (cassette #2). When the program is found, it is loaded into memory.

CSAVE

Save Programs to Cassette

CSAVE-*I* "*filename*"

–*I* is the peripheral specification and specifies REM 1.

filename is the name of your program and must be 16 alphanumeric characters or less. *filename* is optional; if omitted, the program is saved without a filename.

Abbreviations: CS. CSA. CSAV.

CSAVE transfers programs from your Computer's memory to cassette. Note: CSAVE only works with program files. You cannot save data files with CSAVE.

You should give each program file to be saved a filename to distinguish the file from other program or data files on the same cassette.

To use CSAVE:

1. Insert a cassette and rewind the cassette to the position on the cassette where you want to start saving.
2. Press the PLAY and RECORD buttons.
3. If needed, enter the RMT control commands.
4. Enter the filename (and peripheral specification, if any) and press **ENTER** .

5. The cassette starts turning and is saving the program file.
6. Once the Computer has saved the entire program, the prompt will appear on your PC-2.

Special notes about CSAVE:

- You can use CSAVE in the RUN, PRO, or RESERVE modes. Use the RESERVE mode when you are saving reserve programs. Note: In the RESERVE mode, the file that is saved is the defined key data, not the program.
- You should not save programs with the same filename on the same cassette or you may unknowingly transfer the wrong file when using the CLOAD or CHAIN statements (see CLOAD and CHAIN).

Example

```
CSAVE"PROFIT"
```

Saves program "PROFIT" on cassette.

```
CSAVE-1"PROFIT"
```

Saves program "PROFIT" on Remote 1 (cassette #2).

INPUT#

Transfers Data from Cassette to Computer

INPUT#-1, "*filename*"; *variable*, . . .

-1 is the peripheral specification and specifies REM 1.

filename is the name of your data file and must be 16 alphanumeric characters or less; optional, if omitted, the first data file encountered is loaded.

variable is a variable from A-Z or in form of @(), @\$ (), A\$, or AB\$, etc.; and specifies data saved under the variable; optional, if omitted, loads data into fixed data memories. (*) saves all varieties of the variable in both a dimensioned data memory and a fixed data memory.

Abbreviations: I.# IN.# INP.# INPU.#

INPUT# transfers data from cassette to your Computer.

You can use the INPUT# command manually (RUN or PRO mode) or as part of a program. Note: Remember to prepare the Cassette Recorder before you begin to use this command.

With INPUT#, you can read a variable from A-Z; or for fixed data memories, A\$-Z\$; or in the form @() or @\$ (). These variable values specify a segment of the program saved under the variable. With @(), material in parentheses is limited to positive integers from 0-255, or to fixed memories.

Important Note: When attempting to load data into areas of memory other than the fixed data memory, the data array variable must first be dimensioned, using DIM. (See TRS-80 PC-2 Programming Guide for more information on arrays.)

Special Notes about INPUT#:

- Your PC-2 can distinguish and transfer filenames recorded as program and data files even if they have identical filenames.
- If the number of recorded data is smaller than the number of data memory variables specified, error 43 occurs after all the data are transferred into the data memories with the INPUT# statement.
- If the number of recorded data is larger than the number of data memory variables specified, data are transferred until the data memories in the INPUT# statement are loaded, and remaining variables are ignored.
- If a filename you specify is not on cassette, PC-2 continues to search for the absent filename even after the cassette has come to an end.
- When using arrays with INPUT# (you can use either one or two-dimensional arrays), you must use the following syntax or the array will not be loaded from cassette:

```
INPUT# A ( * )
```

Examples

```
INPUT#, "PROGRAM"
```

Tells your Computer to search for the filename and loads data into the specifies variables.

```
INPUT#-1, "PROGRAM"
```

Tells your Computer to search for the filename on Remote 1 (cassette #2) and loads data into the specified variables.

```
INPUT#, "PROGRAM", A, B
```

Transfers only variables A and B from cassette to your Computer's memory.

```
100: INPUT#, "PROGRAM"; A$(20)
```

Recorded data whose filename is "PROGRAM" is put in data memory @\$ (20).

Sample Program

```
10: A=4
```

```
20: B=5
```

```
30: INPUT#, "DATA", A, B
```

The PC-2 INPUTs the values from the cassette and puts them into the variables A and B. These values replace those assigned in line 10 and 20.

MERGE

Appends Cassette Program With Resident Program

```
MERGE "filename"
```

—*I* is the peripheral specification and specifies REM 1.

filename is the name of your program and must be 16 alphanumeric characters or less.

Abbreviations: MER, MERG.

The MERGE statement takes a BASIC program from your cassette and appends it with a resident program in the Computer's memory. MERGE appends this cassette program immediately after the resident program in memory.

Special Notes about MERGE:

- Unlike the CLOAD command, new programs do not replace existing ones.
- You may have duplicate line numbers in memory.
- Only the program loaded from cassette (i.e., the last one entered into RAM) can be edited. When using MERGE, the resident program is "locked" into memory and cannot be edited as the newly-loaded program can.
- When another program is merged and subroutine is performed on the original program with a GOSUB statement, a GOTO statement must be added in the same GOSUB statement line with larger line number than the current line being executed.

Example: 10 "A" : INPUT A
 20 GOSUB "B" : GOTO 30
 30 GOTO 10
 10 "B" PRINT A
 20 RETURN

If GOTO 30 statement is not added, after line 30 GOTO 10, merged program line 10 "B" PRINT A will be executed.

To use MERGE:

1. Set the Remote Switch OFF.
2. Rewind the cassette to the beginning of the area on the cassette where the program is saved and then stop rewinding.
3. Set the Remote Switch ON.
4. Press the PLAY button on your Cassette Recorder.
5. Type: MERGE "filename" **(ENTER)**

When the program is loaded, PC-2's prompt appears on the Display.

Example 1

Let's assume you are writing a program to compute your weekly paycheck and you have written these three lines:

```
10: INPUT "HOURLY RATE: "; R
20: INPUT "NUMBER OF HOURS"; H
30: T=H-40
```

At this point, you remember that you have a similar program portion on cassette under the filename "PAY-CHECK". To see if this six-line program has sections that could be useful in the program you are currently writing, cue the cassette to the place where "PAYCHECK" starts and type:

```
MERGE "PAYCHECK" (ENTER)
```

Your Computer will load "PAYCHECK" into memory immediately behind the program you are currently working on. Your Computer's memory now contains:

```
10: INPUT "HOURLY RATE: "; R
20: INPUT "NUMBER OF HOURS"; H
30: T=H-40

10: "A" INPUT "HOURLY RATE: "; R
20: INPUT "NUMBER OF HOURS"; H
30: T=H-40
```

```
40P=R*40+T*R/2
```

```
50:PRINT "GROSS PAY ="; P
```

```
60:END
```

By chance, this MERGEed program has identical program lines to the one you are currently writing. So, you can continue to write on the program from the newly-loaded "PAYCHECK" file or you can run the program.

Example 2

```
MERGE-1 "PAYCHECK"
```

Appends program file from Remote 1 (cassette #2) into PC-2's memory.

PRINT#

Transfers Data from Computer to Cassette

PRINT#-1, "filename"; variable...

-1 is the peripheral specification and specifies REM 1.

filename is the name of your program and must be 16 alphanumeric characters or less; optional; if omitted, no filename is recorded.

variable is a variable from A-Z, A\$-Z\$, or in the form of @() or @\$ () and specifies a segment of the program saved under the variable; optional, if omitted the all variables in fixed data memory are saved under the filename. (*) saves all varieties of the variable in both a dimensioned data memory and a fixed data memory.

Abbreviations: P.# PR.# PRI.# PRIN.#

The PRINT# command saves the value of a variable or set of variables on cassette. (This is different from CSAVE which saves a program.)

Special notes about PRINT#:

- PRINT# uses the same formats as INPUT#. However, PRINT# transfers data from your Computer to cassette while INPUT# transfers data from cassette to your Computer.
- With PRINT#, you can use a variable. With A (), A\$ (), @ (), @\$ (), or AN\$ (), material in parentheses is limited to positive integers from 0–255, or to fixed memories, such as @. (If memories loaded with program are specified as flexible memories, an error occurs.)
- When using arrays with PRINT# (you can use either one or two-dimensional arrays), you must use the following syntax or the array will not be stored on cassette:

PRINT# A (*)

- The file name represents the contents of a character string or a character variable in quotation marks. (If you try to record or store a character variable without a file name, the character variable is regarded as a file name.) Therefore, be sure to place a file name in such cases.

Example 1: 18 A\$ = "TAPE"

20 PRINT # A\$; X\$

This is identical to PRINT # "TAPE" ; X\$

Example 2: PRINT # X

This records only the contents of numerical variable X without a file name.

Example 3: PRINT # X\$

This statement without a file name will not save the value of the variable X\$. The PC-2 will read X\$ as the file name and since there is no semicolon after the file name, grammar error (ERROR 1) will result. Therefore, if the first variable is a character variable, be sure to place a file name such as: PRINT # "AAA" ; X\$

The purpose of saving data (with PRINT#) is that it lets you use the same data in another program. For example, in the following program, B\$ is the character variable:

```
10:PRINT#,"DECEMBER SALES", B$
```

If you want to save the value of B\$ for use in another program, you can use the PRINT# command. You can use PRINT# in either of two ways:

- Manual (RUN mode. The statement must end with **ENTER**).
- Through a program

Note: Since PRINT# saves data to cassette, you must prepare your Cassette Recorder as you would for CSAVE.

Manual Method of Print#

The manual method offers three options:

Option #1

After running a program, type:

```
PRINT#A,B,C
```

Your Cassette Recorder saves the value of all variables in fixed data memories without a filename on cassette.

Option #2

If you want to identify only certain variables to be saved, type:

```
PRINT#, "PROGRAM"; A, B, C
```

You have specified variables A, B, and C as the ones to be saved in fixed data memory on cassette under the given filename.

Option #3

You can also specify all values of related variables by typing:

```
PRINT#, "PROGRAM"; A( * )
```

The * symbol saves all varieties of "A", including A (1), in a dimensioned data memory; and A (in a fixed data memory).

Program Method of PRINT #

To save through a program with PRINT#, assign a line number to the PRINT# command in your program (using any of the three "Manual" format options discussed above).

When your Computer encounters the specified line number, it will automatically activate your Cassette Recorder and begin to transfer the data to the cassette.

Examples

```
10:A=40,B=3,C=7
```

```
20:PRINT#A,B,C
```

```
30:END
```

Now RUN the program with the Cassette Recorder ready (PLAY and RECORD button pressed). The current values for A, B, and C are stored on cassette.

```
10:PRINT"INTEREST RATE"
```

```
20:INPUT T$
```

```
30:PRINT#T$
```

The value for T\$ is sotred on cassette.

```
10:PRINT"INTEREST RATE"
```

```
20:INPUT T$
```

```
30:PRINT#-1 T$
```

The value of T\$ is stored on Remote 1 (cassette #2).

Sample Session Using INPUT# and PRINT#

Rewind your cassette to the beginning, set the Remote Switch to ON, press the RECORD and PLAY buttons and type in this program:

```
10:A=50,B$="STRING VALUE"
```

```
20:PRINT#A,B$
```

```
30:END
```

Now RUN the program and the variables are saved on your cassette. Clear the memory (NEW **ENTER**). Now set the Remote Switch OFF, rewind the cassette, set the Remote Switch ON, press the PLAY button and type in this program:

```
10:INPUT#A,B$
```

```
20:END
```

Now RUN the program and the values for the A and B\$ are loaded into memory.

Using the Printer

With your Printer and your Computer, you really have the opportunity for two different types of printing — visual, where your result is displayed as charts, drawings, graphs, etc.; and textual, where your result is text such a mathematical sum, an equation, a listing of your program, etc.

With these two different types of printing, there are two modes — TEXT and GRAPH. Use the TEXT mode when you are printing programs, mathematical sums, and other textual items. Use the GRAPH mode when you are drawing lines or illustration, plotting points, and other visual or graphics items.

The TEXT mode is the Printer's normal operating mode (default). The Computer automatically goes into the TEXT Mode on power-up if you turned the Computer's power off with **OFF** (as opposed to letting it shut off automatically).

When you use the two modes there will not be a "mode indicator" on your Printer or on the Computer's Display (as there is with the Computer's PRO or RUN modes, for instance). If you can't remember which mode you are working in, simply reenter the mode.

When you are programming, you'll have to decide which mode you want to be in so your program will run correctly. You can enter both modes by one of two ways:

- Direct Approach — enters the mode directly.
- Program Approach — enters the mode from a program line.

Direct Approach

With the Computer ON, get into the GRAPH mode by typing:

GRAPH **ENTER**

There is a power-up default for the TEXT mode. You can get into the mode by typing:

TEXT **ENTER**

Program Approach

Enter the modes with the first line of your program:

```
10:TEXT
```

```
10:GRAPH
```

Some of the Printer commands can only be used in either mode, while others can be used in both modes (see Printer Commands). Important Note: You must get into the required mode to use a Plotter/Printer command or the command will not execute.

Your Plotter/Printer features:

- TAB command — for indention and middle-of-the-line printing.
- Cartesian plane plotting — graphic displays are printed on an invisible (x, y) plotting system. On all printer commands, range for x is -2048 to $+2047$ and range for y is also -2048 to $+2047$. The system's origin (0, 0) can be set by you or is defaulted to the current pen position. Note: The pen moves a minimum of .2mm each time it moves on the x-axis (horizontal). However, the paper is only 4.32cm. (43.2mm) wide; so (dividing 43.2 by the minimum millimeter pen movement, .2) there are only 216 physically-addressable increments on the x-axis.
- Wrap-around — prints one long program line over several physical lines of the paper.

Printer's Cartesian system:

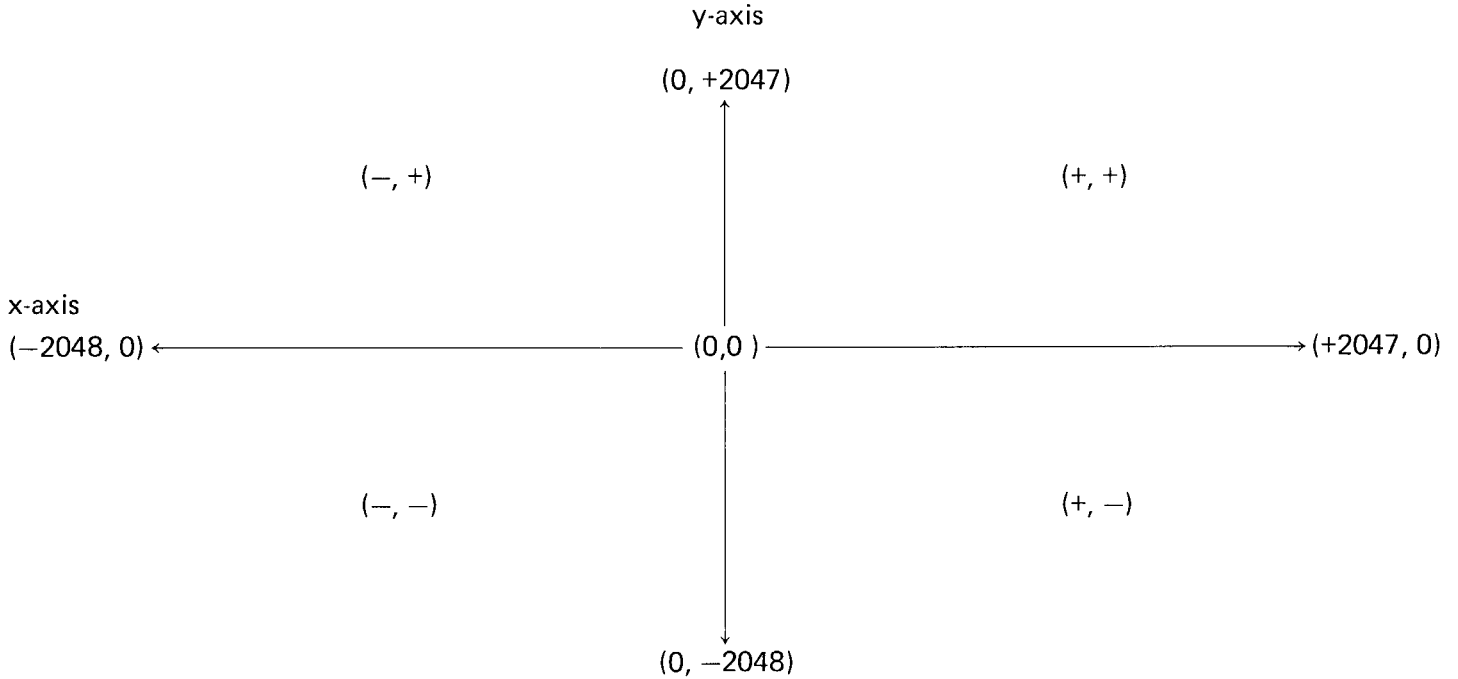
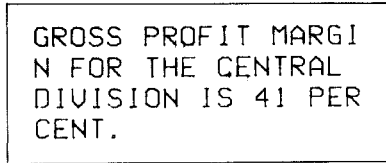

Figure 17

Note: You can set the origin (0, 0) for each command and can be any point on this Cartesian system you want. This chart shows the maximum coordinates possible with the origin centered.

Wrap-Around example:

“GROSS PROFIT MARGIN FOR THE CENTRAL DIVISION IS 41 PERCENT.” This program line is printed over four physical lines on your paper.



```
GROSS PROFIT MARGI  
N FOR THE CENTRAL  
DIVISION IS 41 PER  
CENT.
```

Plotter/Printer Commands

In the following section, we'll discuss the Plotter/Printer commands and how to use them. Each command's respective mode (GRAPH or TEXT) must have been entered or the command will not execute correctly.

Plotter/Printer Commands

Command	Mode
COLOR	GRAPH or TEXT
CSIZE	GRAPH or TEXT
GLCURSOR	GRAPH
LF	TEXT
LINE	GRAPH
LCURSOR	TEXT
LLIST	TEXT (sets Printer to TEXT Mode)
LPRINT	GRAPH or TEXT
RLINE	GRAPH
ROTATE	GRAPH
SORGN	GRAPH
TAB	TEXT
TEST	GRAPH or TEXT

Table 2

COLOR

Rotates Pen Holder to Specified Pen Position

COLOR *pen*

pen is a numeric expression from 0–3 and specifies one of the four pen positions.

Abbreviations: COL. COLO.

COLOR allows you to select the color you want to use for printing. On power-up, 0 is used. Color rotates the pen position (i.e., 0, 1, 2, or 3) to the printing position. The color standard for each position is: black, 0; blue, 1; green, 2, and red, 3.

Important Note: If you enter a number (from 0 through 3) which is not an integer, the number is truncated to the nearest integer (i.e., 1.7 is truncated to 1). All other numbers cause an ERROR 19.

In the TEXT mode, the COLOR command causes the Pen Holder to be reset to the left side of the paper. In the GRAPH mode, the pen returns to its previous position.

Examples

The black pen is in Position #0, blue is in #1, green is in #2, and red is in #3.

10:TEXT

20:COLOR 2

30:LPRINT "GREEN"

Rotates Pen Holder to the green pen.

10:TEXT

20:COLOR 3

30:LPRINT "RED"

Rotates Pen Holder to the red pen.

CSIZE

Sets the Printing Character Size.

CSIZE *size*

size is a numeric expression from 1—9 and specifies the size of the printed character.

Abbreviations: CSI. CSIZ.

CSIZE controls the size of the printing character by determining the character height and width (and consequently, the number of characters per line). On power-up, CSIZE2 is used.

Important Note: LLIST only prints in CSIZE 1 or 2, default is 2.

Character Size Chart

CSIZE	1	2	3	4	5	6	7	8	9
Characters (per line)	36	18	12	9	7	6	5	4	4
Character height (mm)	1.2	2.4	3.6	4.8	6.0	7.2	8.4	9.6	10.8
Character width (mm)	.8	1.6	2.4	3.2	4.0	4.8	5.6	6.4	7.2

Table 3

The character size used to print calculations on the last specified CSIZE command. For example, if the previous character size specified was size 1 or size 2, then this size remains in effect. For LLIST (see LLIST), if the previous size was larger than 2, then the default (size 2) is used.

Examples

```
10:TEXT
```

```
20:CSIZE3
```

```
30:LPRINT"AAAAAAAAAAAAAAAAAAAA"
```

Prints 12 digits to a line. Each digit has a height of 3.6 mm and a width of 2.4 mm.

```
10:TEXT
```

```
20:COLOR 2
```

```
30:FOR I=1 TO 9
```

```
40:CSIZE I
```

```
50:LPRINT"A"
```

```
60:NEXT I
```

Prints nine capital A's of varying sizes downward, starting with smallest and going to largest:

GLCURSOR

Positions Graphic Cursor

GLCURSOR (x, y)

x is a numeric expression from -2048 to $+2047$ and specifies a coordinate on the x-axis.

y is a numeric expression from -2048 to $+2047$ and specifies the coordinates on the y-axis.

Abbreviations: GL. GLU. GLUC. GLCUR. GLCURS. GLCURSO.

GLCURSOR is the GRAPH mode statement and controls the position of printing (the "cursor" position) when working in the GRAPH mode. GLCURSOR moves the pen to the specified position on the x- and y-axes.

Even though the Interface accepts values for x and y from -2048 to $+2047$, the Interface and paper have the following physical limits:

- The Interface only holds 10 cm of paper in reserve for reverse feeding and can only position the Pen Holder (through GLCURSOR) a maximum of 10 cm during reverse (y-axis) line feeding. For large values (e.g., 1500), the pen moves the 10 cm, "counts" to the large value and reads this position (at the physical position of 10 cm on the paper) as the large value (1500).
- There is a 216-increment limit on the physical pen travel on the x-axis. The pen moves a minimum of .2 mm each time it moves one unit on the x-axis (horizontal). However, the paper is only 4.32 cm wide (43.2 mm); so (dividing 43.2 by the minimum pen movement, .2 mm) there are only 216 physically-addressable increments on the x-axis. For large values, the pen moves to the limit (on the right or left margin), "counts" to the large value and reads the position (on the respective margin) as the large value.

Example

```
10:GRAPH
```

```
20:GLCURSOR(100,100)
```

```
30:LPRINT"A"
```

LCURSOR

Positions Cursor

LCURSOR *position*

position is a numeric expression between 0–35 and specifies a printable column. The limit of range is affected by the current CSIZE value.

Abbreviations: LCU, LCUR, LCURS, LCURSO.

CSIZE Value	LCURSOR Position Range
1	0-35
2	0-17
3	0-11
4	0-8
5	0-6
6	0-5
7	0-4
8	0-3
9	0-3

Table 4

LCURSOR is a TEXT mode statement and positions the pen on the paper. The distance the pen moves (with LCURSOR) depends on the current CSIZE.

Movement is one less than the number of characters per line specified by the CSIZE in effect. For example, with CSIZE 1, you can enter a LCURSOR value of up to 35 (the pen can move up to 36 CSIZED-columns if it is currently on the left margin).

With CSIZE 9, you can only enter a LCURSOR value up to 3 since the character size is much larger (and the columns are wider) than for the CSIZE default (2), for instance. For a complete list of CSIZE values, see CSIZE.

Example

```
10:TEXT:CSIZE 2  
20:LCUR.10  
30:LPRINT"FIRST QUARTER SALES"
```

Moves 10 columns from the current pen position and begins printing.

```
10:TEXT:CSIZE 1  
20:LCURSOR5  
30:LPRINT"MONTH"  
40:LCURSOR7  
50:LPRINT"SALES"
```

The pen moves five columns from the current pen position and prints "MONTH" The pen then moves back to left margin, feeds a line, moves seven columns over and prints "SALES".

LF

Line Feed

LF *length*

length is a numeric expression and specifies the line feed increment.

Notes: Even though the Printer will accept a Line Feed value of negative number, it only holds about 10 cm of paper for reverse feeding. Also, you must be in TEXT mode to use Line Feed.

Line Feed causes your paper to move forward or backward. If a positive number is specified, the paper is advanced the specified number of lines. If a negative number is specified, the paper moves back the specified number of lines.

Since the LF command advances the paper the number of lines specified, the actual distance the paper moves depends on the character size currently in effect when you use the LF command (i.e., larger CSIZED-characters take up a larger physical line on the paper since the characters are physically larger). For instance, if you use - 10, the paper will move back that many CSIZED lines (up to the 10 cm max.).

Direction of Paper Feed

End of paper roll (max. 10 cm)

(- direction)

Reverse
Paper Movement

-

-

-

-

0

(pen position)

+

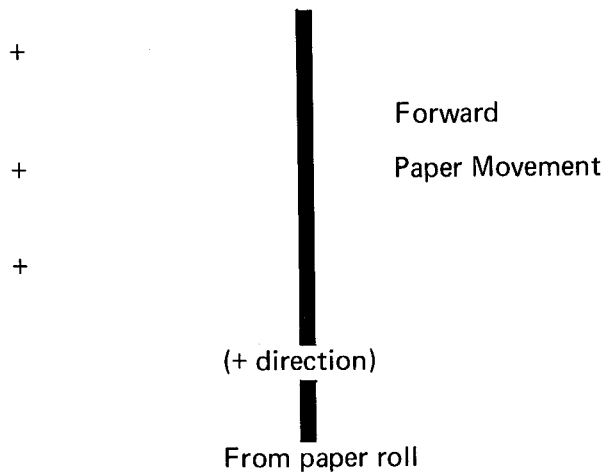

Figure 18

Examples

10:TEXT

20:CSIZE1

30:LF8

Moves the paper forward eight lines corresponding to the CSIZE currently in effect.

10:TEXT

20:CSIZE3

30:LF8

Moves the paper forward eight lines corresponding to the CSIZE currently in effect. Since the CSIZE value is bigger in this example (3 to 1) than the previous one, the paper still moves eight lines but each line takes up more physical space on the paper.

10:TEXT

20:LF-20

Moves the paper backwards 20 lines (up to the 10 cm maximum) corresponding to the CSIZE currently in effect.

LINE

Draws a Line(s)

LINE (x1, y1)–(x2, y2)– . . . (x7, y7), *line style*, *color*, *B*

x is a numeric expression between –2048 and +2047 and specifies a coordinate on the line segment. Only *x2* is mandatory; if *x1* is omitted, the current pen position is used for the starting *x1* (and *y1*) coordinates.

y is a numeric expression between –2048 and +2047 and specifies a coordinate on the line segment. Only *y2* is mandatory; if omitted, the current pen position is used for the starting *y1* (and *x1*) coordinates.

line style is a numeric expression between 0–9 and specifies the kind of lines.

0 — solid line (default on power-up)

1–8 — line style (see chart below)

9 — pen is shifted up, moved and no line is drawn

color is a numeric expression between 0–3 and specifies the color you want for printing. Color is optional; if omitted, default to the currently specified color.

B draws a square, where (x1, y1)–(x2, y2) specifies the endpoints of the diagonal of the square. *B* is optional; if omitted, a straight line is drawn. *B* cannot be used with multiple points (i.e., (x1, y1)–(x2, y2)–(x3, y3)–(x4, y4)). Note: You can use *B* with either of the LINE syntaxes: LINE–(x1, y1) or LINE (x1, y1)–(x2, y2).

Abbreviation: LIN.

LINE draws a line from the point (x1, y1) to the last point which can be up to (x7, y7), allowing a total of six line segments that can be drawn. (x1, y1) specifies the startpoint of the line. If you use the syntax: LINE-(x1, y1)-(x2, y2)-(x3, y3), (0, 0) is used for the startpoint of this line.









Line-style		Line size
0	0 	solid line
1	1 	0.4 mm dash
2	2 	0.6 mm dash
3	3 	0.8 mm dash
4	4 	1.0 mm dash
5	5 	1.2 mm dash
6	6 	1.4 mm dash
7	7 	1.6 mm dash
8	8 	1.8 mm dash
9	9	pen up (no line drawn)

Table 5

Note: You can use LINE to draw a point (or group of points) by using adjacent coordinates in your line statement.

Examples

```
LINE(50,50)-(150,150),4,2
```

Draws a dashed, green line between the specified coordinates. (50, 50) is the startpoint, (150, 150) is the endpoint, 4 specifies the line style, and 2 specifies the color.

```
LINE(100,100)-(200,200),7,3,B
```

Draws a square in red using the specified coordinates as the diagonal endpoints. The four line segments are drawn using the diagonal endpoints as reference but the diagonal line is not physically drawn.



```
LINE-(50,100)-(100,-100)-(-50,-100)
```

Draws two connecting lines, using the current pen position as the startpoint.

```
LINE(100,100)-(101,101)
```

Draws a one-increment line. Because the line's coordinates are adjoining, the line looks like a point.

```
10:GRAPH
```

```
20:GLCURSOR(100,0):SORGN
```

```
30:LINE (50,50)-(-50,50)-(-50,-50)-(50,50)
```

Draws a right triangle.

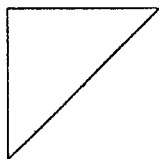

```
10:GRAPH
```

```
20:LINE-(10,10)-(40,40)-(40,70)-(100,50)-(-100,-50)-(0,0)
```

Draws a polygon.

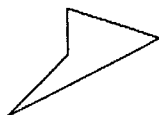

LLIST

Lists Program Lines

LLIST *startline, endline*

startline is the lowest numbered line number to be listed. If omitted, the first line in the program is used.

endline is the highest numbered line number to be listed. If omitted, the last line in the program is used.

LLIST "*label*",

label is the alphabetic indicator that specifies the line to be listed.

Abbreviations: LL. LLI. LLIS.

The LLIST command sets your Printer mode to TEXT. If you were in GRAPH mode and wish to return to this mode, you must reenter the GRAPH command. Important Note: LLIST only prints in CSIZE 1 or 2, default is 2.

LLIST is strictly a line-number listing command. For other printing, you'll use LPRINT (see LPRINT).

Note: Using LLIST with a line number that does not exist will produce an ERROR 11 (if the entered line number is beyond the range of the program lines) or a listing of the line with the next higher line number (if the entered line number is within the range of the program lines). For example, if you have a three-line program numbered 10, 20, and 30, and you enter:

```
LLIST 40
```

you'll get an ERROR 11. But if you enter:

```
LLIST 15
```

the Computer will print the next highest line, line 20.

Examples

```
LLIST
```

Prints the entire program from the first line to the last line.

```
LLIST60
```

Prints line 60.

```
LLIST60,90
```

Prints lines 60 through 90.

```
LLIST60,
```

Prints line 60 through the last line of the program.

```
LLIST ,90
```

Prints first line through line 90.

Examples (using a "label" in a program line)

```
10: SAMPLE PROGRAM
```

```
20: "A" PROGRAM LINE
```

```
30: CSIZE 3
```

```
40: LPRINT "LABEL WITH LLIST"
```

```
LLIST "A"
```

Lists the line with the label (which, in this example, is line 20).

```
LLIST "A",
```

Lists the line with the label through the end of the program.

(For more information about labels, see your PC-2's Owner's Manual.)

LPRINT

Prints an Item

LPRINT *item delimiter item delimiter . . .*

item is a list composed of strings or numeric expressions; optional, if omitted, moves pen from "current" coordinates to the left margin of the paper and reads the coordinates at the margin as the previous "current" coordinates.

delimiter is a comma or semi-colon.

Abbreviation: LP. LPR. LPRI. LPRIN.

LPRINT is the command for displaying alphanumeric information on your Printer. LPRINT incorporates USING which operates in the same manner as it does in the PRINT statement (see the PC-2 Owner's Manual for a description of PRINT USING).

To help you understand LLIST and LPRINT, you should know that listing data to your Printer is similar to listing items to your Pocket Computer's screen. There are two Printer commands that correspond to the PC-2 print commands.

Display Commands vs. Printer Commands	
PRINT	LPRINT (Outputs to Plotter/Printer)
LIST	LLIST (Prints Program Lines)

Table 6

Special notes about LPRINT:

- A special feature of your Interface lets you print even with the Print Switch set to AUTO by using LPRINT. Other commands which cause printing or drawing (LLIST, LINE, etc.) can also be used when the Print Switch is set to AUTO.
- A numeric expression is right justified and a string is left justified (from the pen position). When the item list is longer than a physical line on the paper, the Printer performs a carriage return and wraps-around.
- If the Pen Holder is not positioned on the left side of the paper, printing begins from the current pen position.
- Non-numeric text must be enclosed in quotation marks (e.g., LPRINT"PROGRAM"). Alphanumeric (string) variables (LPRINTA#) and numbers (LPRINT7777) do not need quotation marks.
- If you try to print a number which is too big to fit on one line because of the current character size (see CSIZE), the character is cutoff at the right margin and the digits wrap-around. If the same conditions exist when printing a character string instead of a number, the string is continued on the next line.

There are two types of delimiters with LPRINT: comma and semi-colon. If the delimiter is a comma (e.g., LPRINT"AA",4):

- LPRINT justifies the numeric expression on the right margin of one line and the string on the left margin of another line.
- The order of printing is determined by the order of the items within the LPRINT statement.
- For larger character sizes, the two items are printed on two successive lines.
- If two strings are used (e.g., LPRINT"AAAAA", "BBBBB"), they are both left justified on two different lines. If either is too long, only that part of the respective string that fits on the line is printed.

Note: The comma can be used in TEXT mode only.

If the delimiter is a semi-colon (e.g., LPRINT"AA";4):

- Items are printed on the same line (while the comma delimiter prints the item on different lines).
- If the total length of items exceeds the capacity of the physical line, the items are printed on as many successive lines as necessary.

Examples of String/Numeric Justification:

```
LPRINT"AAAA",7
```



LPRINT7, "AAAA"

AAAA	7
------	---

LPRINT with two item lists (i.e., LPRINT item list, item list), that are strings, prints each list on a separate line (see LPRINT "PROGRAMI", "PROGRAMII" examples below).

Example

LPRINT8888

8888

LPRINT"PC-2"

PC-2

LPRINT"PROGRAMI", "PROGRAMII"

PROGRAMI
PROGRAMII

```
LPRINT"AAA":33
```



AAA 33

Examples

```
10:GRAPH:SORGN
```

```
20:GLCURSOR(30,0):LPRINT"CAR SALES UP"
```

Moves Pen Holder to the specified coordinates and prints "CAR SALES UP"

```
10:A$="EXAMPLE"
```

```
20:B=123456
```

```
30:FOR I=1 TO 3
```

```
40:CSIZE I
```

```
50:LPRINT A$
```

```
60:LPRINT A$,B
```

```
70:LPRINT A$;B
```

```
80:LF 5
```

```
90:NEXT I
```

Line feeds five lines and prints the following in CSIZE 1, 2 and 3:

EXAMPLE
EXAMPLE
EXAMPLE 123456

123456

EXAMPLE
EXAMPLE

123456

EXAMPLE 123456

EXAMPLE
EXAMPLE

123456

EXAMPLE 1234

56

RLINE

Draws Line From Relative Origin

RLINE—(x1, y1)—(x2, y2)— . . . (x7, y7), *line style*, *color*, *B*

x is a numeric expression between -2048 and +2047 and specifies a coordinate on the line segment. The current pen position is the relative origin for the first line segment. Only x1 is mandatory.

y is a numeric expression between -2048 and +2047 and specifies a coordinate on the line segment. The current pen position is the relative origin for the first line segment. Only y1 is mandatory.

line style is a numeric expression between 0-9 and specifies the kind of lines to be drawn; optional.

0 — solid line (default on power-up)

1-8 — *line style* (see chart with LINE)

9 — pen is shifted up and moved

color is a numeric expression between 0-3 and specifies the color you want for printing. *Color* is optional; if omitted, defaults to currently specified color.

B draws a square, where relative origin and (x1, y1) specify the endpoints of the diagonal of the square. *B* is optional; if omitted, a straight line is drawn. *B* cannot be used with RLINEs with multiple points (i.e., RLINE—(x1, y1)—(x2, y2)—(x3, y3)). Note: You can use B with either of the RLINE syntaxes (RLINE—(x1, y1) or RLINE (x1, y1)—(x2, y2))

Abbreviations: RL. RLI. RLIN.

RLINE is similar to the LINE statement except that RLINE draws a line using the current position of your pen as the relative origin (0, 0). RLINE is convenient to use when you want to draw a series of lines using the current pen position as the starting point.

Since only the coordinates (x1, y1) are mandatory when using RLINE, you can draw a line using only this one set of coordinates with the current pen position's coordinates. For example, RLINE-(50, 50) uses the current pen position for the startpoint as it draws the line.

Examples

```
10:GRAPH
```

```
20:LINE-(50,100)-(75,75)
```

```
30:RLINE-(100,100)
```

Draws a line with three line segments: (0, 0)-(50, 100), (50, 100)-(75, 75), and (75, 75)-(100, 100). The minus sign (-) after LINE, specifies the current pen position as the startpoint. On the RLINE statement, (75, 75) is used as the relative origin since it is the current pen position.

```
10:GRAPH
```

```
20:LINE-(10,10)
```

```
30:RLINE-(25,25)-(50,50)-(100,100)-(120,100)-(140,100)-(150,150),4,3
```

Draws a diagonal line. The first segment is in the currently specified color, the next segments are in red with line style #4. The coordinates (10, 10) are used as the relative origin.

```
10:GRAPH
```

```
20:LINE-(30,30)
```

```
30:RLINE-(60,60)-(60,-120)-(-60,-60),3,3
```

The LINE statement draws a diagonal line from (0, 0) to (30, 30). The RLINE statement draws three line segments using in red (pen position #3) and line style #3. The coordinates (30, 30) are used as the relative origin for RLINE.

```
10:GRAPH
```

```
20:LINE(10,10)-(50,50)
```

```
30:RLINE-(100,100),,,B
```

Draws a square. The startpoint is (50, 50) and the endpoint is (100, 100). This endpoint of the diagonal line is used for the startpoint for the box. The square is drawn using the coordinates, (50, 50) and (100, 100), for the length of the sides.

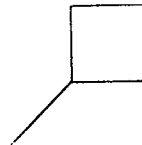

```
10:GRAPH
```

```
20:RLINE(80,80)-(110,110),5,2,B
```

```
30:END
```

Draw a square in green with line style #5, using the coordinates, (80, 80) and (110, 110), for the length of the sides.

ROTATE

Sets Printing Direction

ROTATE *direction*

direction is a numeric expression between 0–3 and specifies the direction of printing. The four directions are: right (0), down (1), left (2), and up (3).

Abbreviations: RO. ROT. ROTA. ROTAT.

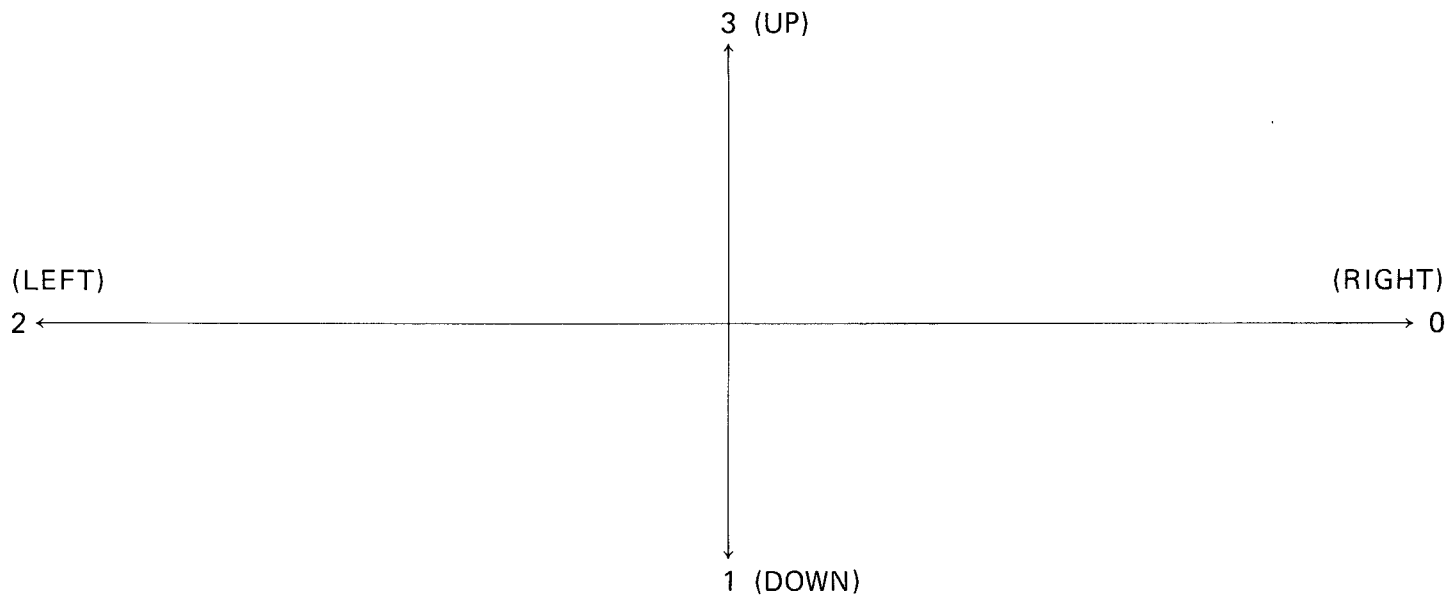

Figure 19

Use ROTATE when you want to have a different direction of Printing from the default (0, left to right).

Position	Printing Direction
ROTATE 0	Prints the width of your paper (to right end).
ROTATE 1	Prints downward to -2047 (41 cm).
ROTATE 2	Prints the width of your paper (to left end).
ROTATE 3	Prints upward for a maximum of about 10 cm. (The actual number of line feeds depends on the value of CSIZE currently in effect.)

Table 7

Examples

```
10:GRAPH  
20:ROTATE 1  
30:LPRINT"ABCDE"  
40:END
```

Prints characters downward from the current position.

```
10:GRAPH  
20:ROTATE 0  
30:LPRINT"ABCDE"
```

Prints characters left to right from current position.

```
10:GRAPH  
20:GLCURSOR(100,0)  
30:FOR I=0 TO 3  
40:ROTATE I  
50:LPRINT "ABCDE"  
60:NEXT I
```

Prints "ABCDE" in four directions (right, down, left, and up).

SORGN

Sets Origin

SORGN

Abbreviations: SO. SOR. SORG.

Use SORGN to set the current pen position as the home (origin) position. SORGN is convenient to use when you are plotting lines and you want to set an origin. When you use SORGN, you set the current pen position as the origin.

SORGN is extremely convenient to use when you are drawing a series of lines. This command lets you set the origin anywhere on your Printer's invisible Cartesian (x, y) plane:

Example

```
10:GRAPH
```

```
20:GLCURSOR(50,50)
```

```
30:SORGN
```

Sets origin at specified coordinates: (50, 50).

TAB

Positions Pen

TAB *position*

position is a numeric expression between 0–35 for the number of pen movements. Maximum values for *position* is determined by the current value of CSIZE (*position* is one less than the number of characters per line in the current CSIZE).

TAB moves the pen horizontally from the current position to the column number specified by the number (*position*). TAB's range is inversely proportional to the value of CSIZE; as the character size is larger, the range of TAB is smaller.

When using LPRINT with TAB:

- Non-numeric data (e.g., "PROGRAM LINE") must be in quotation marks or the listing will not be printed out.
- Numeric data (e.g., 1122) does not need quotation marks.

Examples

```
10:TEXT
```

```
20:CSIZE 7
```

```
30:LPRINT TAB 5: 6
```

```
40:END
```

Moves pen over five CSIZE 7 columns and prints "6"

10:TEXT

20:CSIZE 5

30:TAB 4

40:END

Moves pen over four CSIZE 5 columns.

10:TEXT

20:CSIZE 2

30:LPRINT TAB 8:"JANUARY SALES UP 35 PERCENT OVER DECEMBER"

40:END

Moves pen over eight CSIZE 2 columns. Prints listing beginning at the eight column and spreads the listing over three physical lines.

TEST

Self-Test

TEST

Abbreviations: TE. TES.

Use to check printer color and dryness of the pen ink. Four 5mm x 5mm "test squares" are printed horizontally, using one pen from each position to draw each square. TEST works from either mode. Note: If you use TEST in the GRAPH mode, the four colored test squares are printed and the pen returns to the left margin and the mode is reset to TEXT.

Example

TEST

4/Care and Maintenance

Tips for a trouble-free Interface:

- The PC-2 (which controls the Interface's power), must always be OFF while connecting or disconnecting the AC adapter or the PC-2.
- As a high-quality compact graphics printer, the Printer/Cassette Interface must operate on level surfaces which are free of vibrations.
- Keep the Printer away from extreme temperature changes, moisture, and dust.
- Use a soft, dry cloth to clean the Interface. Do not use solvents or a wet cloth.
- Do not touch the Pen Holder, Printing Mechanism, or other internal parts. Incorrect handling might damage the calibration (resulting in an error, particularly in graphics) or result in pen dislocation.
- Keep foreign objects out of the Printer.
- Should a pen drop inside the Printer, turn the unit over and the pen should drop out.
- Remove the pens upon completing your printing. Then cap the pens and place them in their pen cases for storage. When the pens have been in the Printer for a long time, the ink will dry up.

Caution! If the PC-2 receives strong static electricity or external noise, the display may change or keys may not operate. If this happens, press the ALL RESET button (if necessary, refer to your PC-2 Owner's Manual). As a precaution, we recommend that you save all your data and programs on cassette.

Common Problems

If the Printer malfunctions, the error will be listed on your Computer's display. Check the following troubleshooting list for a solution. (A complete list of Interface error messages is in Appendix B.)

CHECK 6 — When **CHECK 6** (6 is a number which represents the Interface) is displayed with the Computer turned ON, the Interface is not fully charged or the Printer is malfunctioning. With **CHECK 6** on the display, do not operate the Printer or any of the Printer's keys. Charge the Printer.

ERROR 78 OR 80 — If any of these errors are displayed, be sure to turn the Printer/Computer power OFF by pressing **OFF**. With the power ON, misoperation may result (e.g., no sound occurs under BEEP instruction or no accurate displays are possible).

Troubleshooting Checklist

Display	Cause	Remedy
CHECK 6 NEW 0?: CHECK 6	<ul style="list-style-type: none"> (1) Voltage of internal rechargeable battery drops. (2) No pen position detecting color signals is generated. If a pen or any object drops inside the Printer, the Pen Holder does not rotate or move. 	<p>Charge battery.</p> <p>Turn the Computer OFF and remove any object from the Printer.</p>
ERROR 78	<ul style="list-style-type: none"> (1) The printer is in the Pen Replacement Mode. (2) The Printer locked by low battery check (ERROR 80) remains unlocked. 	<p>Pressing the  button with the (CL) pressed, clears the Pen Replacement Mode.</p> <p>After charging the battery, press the (OFF) and (ON) to lock the Printer.</p>
ERROR 80 (battery check)	The voltage of internal rechargeable battery drops.	Charge the battery. Unlock the Printer by pressing (OFF) and (ON) .

Table 8

If CHECK 6, ERROR 78, or 80 is displayed even after troubleshooting the causes, see your Radio Shack Computer Center dealer. For a complete list of the Interface errors, see Appendix B.

5/Specifications

Model:	Radio Shack Catalog Number 26-3605 PC-2 Printer/Cassette Interface.
Printer:	Four, water-color pens (black, blue, green, and red) included. Two three-pen replacement packages (red, green, and, blue — Radio Shack Cat. No. 26-1481; and three black — Radio Shack Cat. No. 26-1480)
Print system:	x- and y-axis plotter system. Four directions — up, down, left, and right.
Print Characters:	ASCII set.
Character Size:	9 sizes from 1.2 mm (.047 inch) x 0.8 mm (0.031 inch) to 10.8 mm (.425 inch) x 7.2 mm (.283 inch).
Pen Shift Minimum:	0.2mm (.008 inch)
Printing Speed:	11 characters max./second when printing the smallest characters. (The print speed varies with the size of print characters.)
Printing Paper:	Radio Shack Catalog Number 26-3606 57mm (2-1/4") wide. 30mm (1-3/16") in diameter (max.)
Power Source:	Built-in rechargeable Ni-Cd battery pack and AC adapter.

Battery Capacity: Approx. 1,100 lines
 Charging time approx. 15 hours.

Power Consumption: 5.2W (DC)

Temperatures: Operation: 5°C to 40°C (41°F to 102°F)
 Storage: -10°C to 50°C (14°F to 122°F)

Humidity: Operation: 40 to 80%
 Storage: 20 to 90% (non-condensing)

Dimensions: 330mm (width) x 115mm (depth) x 50mm (height)
 13" (width) x 4-17/32" (depth) x 1-31/32" (height)

Weight: 1.98 pounds (excluding accessories) 900 g.

Accessories: 3 rolls of paper Radio Shack Cat. No. 26-3606
 AC adapter

Appendix A/Language Reference Summary

Argument ranges are indicated below by special letters or words:

color : numeric expression from 0–3

delimiter : comma or semi-colon

length : numeric expression from –2048 to +2047

line number : numeric expression from 1–65, 279

line style : numeric expression from 0 to 9

position : numeric expression from 1–36

size : numeric expression from 1–9

x : numeric expression from –2048 to +2047

y : numeric expression from –2048 to +2047

		Page
CHAIN-1 " <i>filename</i> ", <i>line number</i>	Loads program segments and executes. Program statement only.	35
Abbreviations: CHA. CHAI.		
100:CHAIN"PROG1",30	100:CHAIN"PROG2",A	100:CHAIN-1"PROG1"
CLOAD-1 " <i>filename</i> "	Loads program from cassette. Abbreviations: CLO. CLOA.	41
CLOAD CLOAD"PROG"	CLOAD-1"PROG"	

	Page
CLOAD?-1 <i>"filename"</i> Compares cassette program with resident program. Abbreviations: CLO.? CLOA.? CLOAD? CLOAD?"PROG" CLOAD?-1"PROG"	40
COLOR <i>pen</i> Rotates pen holder to specified pen position. Abbreviations: COL. COLO. COLOR3	62
CSAVE-1 <i>"filename"</i> Saves program on cassette. Abbreviations: CS. CSA. CSAV. CSAVE"PROG" CSAVE-1"PROG"	44
CSIZE <i>size</i> Sets the printing character size (1-9). Abbreviations: CSI. CSIZ. CSIZE3	63
GLCURSOR (<i>x, y</i>) Positions graphic cursor. Abbreviations: GL. GLC. GLCU. GLCUR. GLCURSOR(100,100)	66
GRAPH Enters GRAPH mode. Abbreviation: GRAP. GRAPH 10:GRAPH	57
INPUT#-1 , <i>"filename", variable, ...</i> Transfers data from cassette to memory. Abbreviations: I.# IN.# INP.# INPU.# IN.#, "PROG" 100:INPUT#, "PROG", A, B INPUT#-1, "PROG"	46
LCURSOR <i>position</i> Positions cursor. Abbreviations: LCU. LCUR. LCURS. LCURSO. LCURSOR6	67

	Page
LF <i>length</i> Line Feed command. Reverse paper movement cannot be greater than 10 cm. LF8 LF-5	70
LINE <i>-(x1, y1)- . . . (x7, y7), line style, color, B</i> LINE <i>(x1, y1)- . . . (x7, y7), line style, color, B</i> Draws a line (or lines). Abbreviation: LIN. LINE(50,50)-(100,100),3,1	74
LLIST <i>startline, endline</i> LLIST <i>"label",</i> Lists program lines to the Printer. Abbreviations: LL, LLI, LLIS. LLIST LLIST600 LLIST600,900 LLIST "A"	78
LPRINT <i>item delimiter item delimiter . . .</i> Prints an item. Abbreviations: LP, LPR, LPRI, LPRIN. LPRINT"FF",66 LPRINTA#;B;C	81
MERGE-1 <i>"filename"</i> Appends cassette program with resident program. Abbreviations: MER, MERG. MERGE"PROG" MERGE-1"PROG"	48
PRINT#-1, <i>"filename"; variable, . . .</i> Transfers data from Computer to cassette. Abbreviations: P.# PR.# PRI.# PRINT# PRINT#"PROG" 10:PR.#"PROG" P.#"PROG",A,B,C PRINT#-1"PROG"	51

RLINE—(x1, y1)— . . . (x7, y7), *line style, color, B*

RLINE (x1, y1)— . . . (x7, y7), *line style, color, B*

Draws line from relative origin. Abbreviations: RL. RLI. RLIN.

RLINE—(100, 100) RLINE(60, 60)—(120, 120)

RLINE—(120, 120), 5, 2, B RLINE—(50, 50)—(100., 100)

RMT *switch* Disables/enables Remote Switch (REM 1 only) Abbreviations: RM.OF. RMTOF.
RM.O. RMTO.

30

RMT OFF RMT ON

ROTATE *direction* Sets printing direction. Abbreviations: RO. ROT. ROTA. ROTAT.

92

ROTATE2

SORGN Sets origin. Abbreviations: SO. SOR. SORG.

96

SORGN

TAB *position* Positions pen.

97

TAB 5 LPRINT TAB6;7 LPRINT TAB5;"PROGRAM"

TEST Self-test. Abbreviations: TE. TES.

99

TEST

TEXT Enters TEXT mode. Abbreviation: TEX.

57

TEXT 10:TEXT

Appendix B/Error Codes

The following is a list of Interface errors. If you get another error, check your PC-2 Owner's Manual for a description of the error.

Important Notes: Entering the incorrect abbreviation for a Interface command will give you an error. You'll also receive errors if you attempt to enter a Cassette command and your Cassette Recorder is not connected or if you attempt to enter a Printer command and your Interface is not connected.

Error Code	Explanation
1	Syntax or incorrect mode error.
11	Line number does not exist.
40	Inappropriate specification for the expression.
41	SAVE and LOAD have been specified for the ROM area.
42	Cassette file data is too large and cannot be LOADED.
43	When verifying data using the CLOAD? command, the format of data to be loaded does not match the file format.
44	A checksum error has occurred.
70	The pen has exceeded or reached the limit of the coordinate range ($x > -2048$ and $y < +2047$).

Error Code	Explanation
71	Paper has exceeded or reached the reverse line feed limit of 10 cm.
72	Value given is inappropriate for the value of TAB.
73	Command has been used in the wrong Printer mode.
74	Too many commas in LINE or RLINE statement. Entry of over seven commas gives an error. If the first comma is omitted, more than six gives an error.
76	Using LPRINT, results cannot be printed on one line in TEXT mode.
78	Pens are in the process of being changed or the Low Battery State has not been corrected. Error occurs when commands that move the pen can not be executed.
79	PC-2 has not received a "color signal." The signal goes ON when the Interface is turned ON and the pen moves to the left margin of the paper.
80	Low battery.
CHECK 6 NEW0? : CHECK	Printer is not fully charged.

SERVICE POLICY

Radio Shack's nationwide network of service facilities provides quick, convenient, and reliable repair services for all of its computer products, in most instances. Warranty service will be performed in accordance with Radio Shack's Limited Warranty. Non-warranty service will be provided at reasonable parts and labor costs.

Because of the sensitivity of computer equipment, and the problems which can result from improper servicing, the following limitations also apply to the services offered by Radio Shack:

1. If any of the warranty seals on any Radio Shack computer products are broken, Radio Shack reserves the right to refuse to service the equipment or to void any remaining warranty on the equipment.
2. If any Radio Shack computer equipment has been modified so that it is not within manufacturer's specifications, including, but not limited to, the installation of any non-Radio Shack parts, components, or replacement boards, then Radio Shack reserves the right to refuse to service the equipment, void any remaining warranty, remove and replace any non-Radio Shack part found in the equipment, and perform whatever modifications are necessary to return the equipment to original factory manufacturer's specifications.
3. The cost for the labor and parts required to return the Radio Shack computer equipment to original manufacturer's specifications will be charged to the customer in addition to the normal repair charge.

RADIO SHACK, A DIVISION OF TANDY CORPORATION
U.S.A.: FORT WORTH, TEXAS 76102
CANADA: BARRIE, ONTARIO L4M 4W5

TANDY CORPORATION

AUSTRALIA

280-315 VICTORIA ROAD
RYDALLMEERE, N.S.W. 2116

BELGIUM

PARC INDUSTRIEL DE NANINNE
5140 NANINNE

U. K.

BILSTON ROAD WEDNESBURY
WEST MIDLANDS WS10 7JN